

MANUALE TECNICO PULEGGE

ed. 02 2010



PI PULLEY



PIZZIRANI

Le pulegge "P PULLEY" sono prodotte secondo la normativa internazionale BS 3790-1981 - DIN 2211 - ISO 4183. Tutte le pulegge sono costruite in ghisa grigia GG25 con trattamento superficiale di fosfatazione di colore nero. Sono adatte per funzionare sino ad una velocità periferica di 30 mt/sec. Oltre questa velocità periferica consigliamo la costruzione delle stesse con materiali ad alta resistenza. Le nostre pulegge vengono equilibrate con il grado ISO G16".

P-Pulleys are produced according to the international regulations BS 3790-1981-DIN 211-ISO 4183. Those pulleys are made of GG25 grey cast iron and a special black phosphating treatment on the surface is added. They can be used up to a peripheric speed of 30 mt/sec. Beyond this limit it is advised to use high resistance materials. Our pulleys are balanced according to the ISO G16 standard.

Le bussole coniche P BUSH sono prodotte in ghisa grigia GG25. Tutte le bussole coniche P BUSH vengono fornite complete di foro alesato con tolleranza H7, cava chiavetta (tabella a pagina 13) e il set di viti completo per il fissaggio sulla puleggia.

P-bushes are made of GG25 grey cast iron. They have a H7- shaped bore and key way (see the chart at page 13) and a complete set of screws to be fixed at the pulley.

1

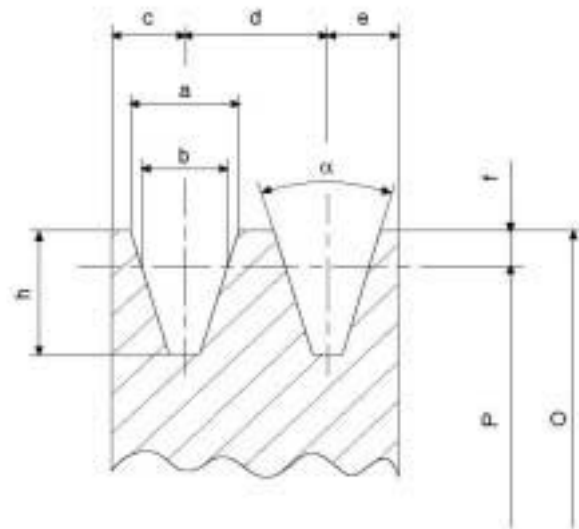

DIMENSIONI DELLE GOLE:

Z - A - B - C - SPZ - SPA - SPB - SPC

Conforme alle seguenti norme internazionali:

DIN 2211 - ISO 4183

Dimensioni pulegge • Pulley dimension

	a	b	c	d	e	f	h	34°	38°
Z-SPZ-3V	9,7	8,5	8	12	8	2	11	P<=80	P >80
A-SPA	12,7	11	10	15	10	2,8	13,8	P<=118	P >118
B-SPB-5V	16,3	14	12,5	19	12,5	3,5	17,5	P<=190	P >190
C-SPC	22	19	17	225	17	4,8	23,8	P<=315	P >315

V-Belt pulleys for taper bush according to ISO4183 and DIN2211 norms

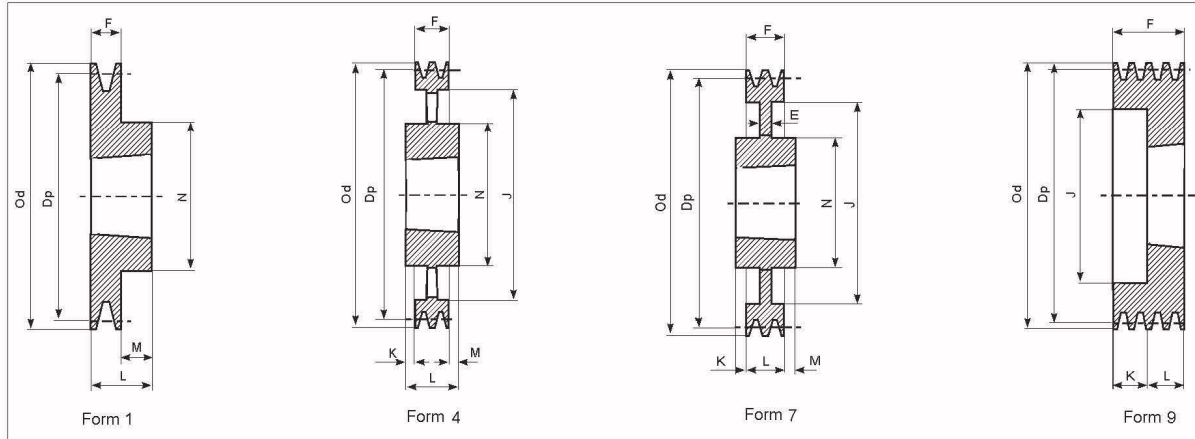

SPZ - 1

Description	Dp.	Od.	Form	Bush No.	Max Bore	E	F	J	K	L	M	N
SPZ 50 - 01	50	54	9	1008	25		37	28	15	22		
SPZ 56 - 01	56	60	9	1008	25		37	23	15	22		
SPZ 60 - 01	60	64	2	1008	25		22			22		
SPZ 63 - 01	63	67	1	1108	28		16			22	6	62
SPZ 67 - 01	67	71	1	1108	28		16			22	6	62
SPZ 71 - 01	71	75	1	1108	28		16			22	6	62
SPZ 75 - 01	75	79	1	1108	28		16			22	6	62
SPZ 80 - 01	80	84	1	1210	32		16			25	9	75
SPZ 85 - 01	85	89	1	1210	32		16			25	9	75
SPZ 90 - 01	90	94	1	1210	32		16			25		75
SPZ 95 - 01	95	99	1	1210	32		16			25	9	75
SPZ 100 - 01	100	104	1	1210	32		16			25	9	75
SPZ 106 - 01	106	110	1	1610	42		16			25	9	80
SPZ 112 - 01	112	116	1	1610	42		16			25	9	80
SPZ 118 - 01	118	122	1	1610	42		16			25	9	80
SPZ 125 - 01	125	129	1	1610	42		16			25	9	80
SPZ 132 - 01	132	136	1	1610	42		16			25	9	80
SPZ 140 - 01	140	144	1	1610	42		16			25	9	80
SPZ 150 - 01	150	154	1	1610	42		16			25	9	80
SPZ 160 - 01	160	164	1	1610	42		16			25	9	80
SPZ 170 - 01	170	174	1	1610	42		16			25	9	80
SPZ 180 - 01	180	184	1	1610	42		16			25	9	80
SPZ 190 - 01	190	194	7	1610	42		16	161		25	9	80
SPZ 200 - 01	200	204	7	2012	50		16	172		32	16	100
SPZ 212 - 01	212	216	7	2012	50		16	172		32	16	100
SPZ 224 - 01	224	228	7	2012	50	15	16	196		32	16	100
SPZ 250 - 01	250	254	4	2012	50		16	222	8	32	8	100
SPZ 280 - 01	280	284	4	2012	50		16	252	8	32	8	100
SPZ 315 - 01	315	319	4	2012	50		16	287	8	32	8	100
SPZ 355 - 01	355	359	4	2012	50		16	326	8	32	8	112
SPZ 400 - 01	400	404	4	2012	50		16	371	8	32	8	112
SPZ 450 - 01	450	454	4	2517	60		16	421	14,5	45	14,5	120

V-Belt pulleys for taper bush according to ISO4183 and DIN2211 norms

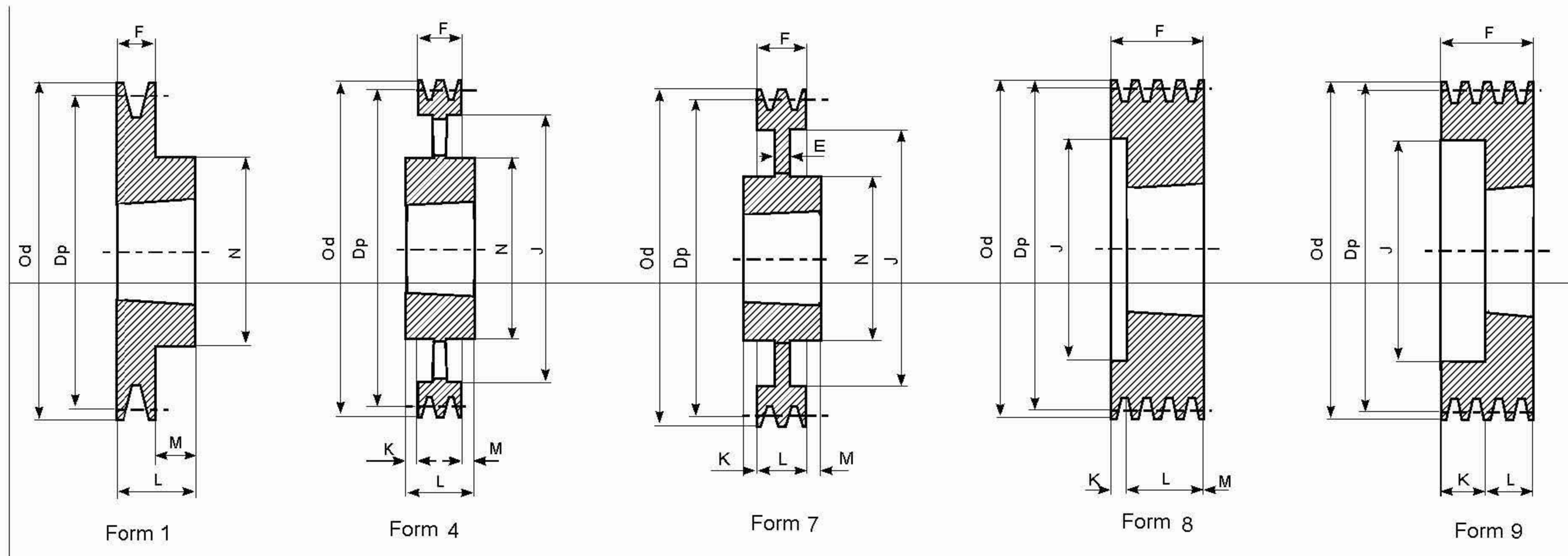

SPZ - 2

Description	Dp.	Od.	Form	Bush No.	Max Bore	E	F	J	K	L	M	N
SPZ 50 - 02	50	54	9	1008	25		49	28	27	22		
SPZ 56 - 02	56	60	9	1108	28		49	35	27	22		
SPZ 60 - 02	60	64	9	1108	28		49	36	27	22		
SPZ 63 - 02	63	67	8	1108	28		28	40	6	22		
SPZ 67 - 02	67	71	8	1108	28		28	42	6	22		
SPZ 71 - 02	71	75	8	1108	28		28	42	6	22		
SPZ 75 - 02	75	79	8	1210	32		28	51	3	25		
SPZ 80 - 02	80	84	8	1210	32		28	51	3	25		
SPZ 85 - 02	85	89	8	1610	42		28	60	3	25		
SPZ 90 - 02	90	94	8	1610	42		28	61	3	25		
SPZ 95 - 02	95	99	8	1610	42		28	66	3	25		
SPZ 100 - 02	100	104	8	1610	42		28	71	3	25		
SPZ 106 - 02	106	110	8	1610	42		28	76	3	25		
SPZ 112 - 02	112	116	8	1610	42		28	84	3	25		
SPZ 118 - 02	118	122	8	1610	42		28	90	3	25		
SPZ 125 - 02	125	129	8	1610	42		28	97	3	25		
SPZ 132 - 02	132	136	8	1610	42		28	104	3	25		
SPZ 140 - 02	140	146	8	1610	42		28	115	3	25		
SPZ 150 - 02	150	154	1	2012	50		28			32	4	100
SPZ 160 - 02	160	164	1	2012	50		28			32	4	100
SPZ 170 - 02	170	174	1	2012	50		28			32	4	100
SPZ 180 - 02	180	184	7	2012	50	10	28	152		32	4	100
SPZ 190 - 02	190	194	7	2012	50	10	28	161		32	4	100
SPZ 200 - 02	200	204	7	2012	50	10	28	171		32	4	100
SPZ 224 - 02	224	228	7	2012	50	10	28	196		32	4	100
SPZ 250 - 02	250	254	4	2012	50		28	222	2	32	2	100
SPZ 280 - 02	280	284	4	2012	50		28	252	2	32	2	100
SPZ 315 - 02	315	319	4	2012	50		28	286	2	32	2	100
SPZ 355 - 02	355	359	4	2012	50		28	326	2	32	2	112
SPZ 400 - 02	400	404	4	2517	50		28	371	8,5	45	8,5	120
SPZ 450 - 02	450	454	4	2517	60		28	421	8,5	45	8,5	120

V-Belt pulleys for taper bush according to ISO4183 and DIN2211 norms

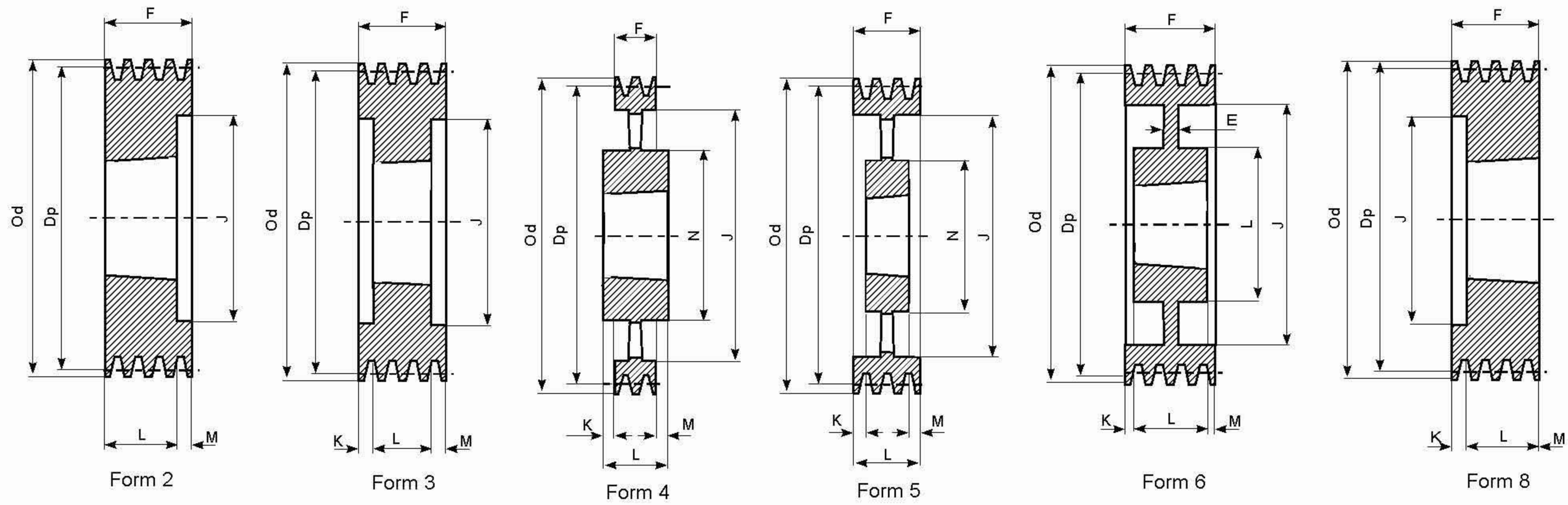

SPZ - 3

Description	Dp.	Od.	Form	Bush No.	Max Bore	E	F	J	K	L	M	N
SPZ 63x3	63	67	8	1108	28	-	40	40	-	22	-	-
SPZ 67x3	67	71	8	1108	28	-	40	42	18	22	-	-
SPZ 71x3	71	75	8	1108	28	-	40	42	18	22	-	-
SPZ 75x3	75	79	8	1210	32	-	40	51	15	25	-	-
SPZ 80x3	80	84	8	1210	32	-	40	51	15	25	-	-
SPZ 85x3	85	89	8	1610	42	-	40	60	15	25	-	-
SPZ 90x3	90	94	8	1610	42	-	40	61	15	25	-	-
SPZ 95x3	95	99	2	1610	42	-	40	66	-	25	15	-
SPZ 100x3	100	104	2	1610	42	-	40	71	-	25	15	-
SPZ 106x3	106	110	2	1610	42	-	40	76	-	25	15	-
SPZ 112x3	112	116	2	2012	50	-	40	83	-	32	8	-
SPZ 118x3	118	122	2	2012	50	-	40	90	-	32	8	-
SPZ 125x3	125	129	2	2012	50	-	40	96	-	32	8	-
SPZ 132x3	132	136	2	2012	50	-	40	103	-	32	8	-
SPZ 140x3	140	144	2	2012	50	-	40	111	-	32	8	-
SPZ 150x3	150	154	2	2012	50	-	40	121	-	32	8	-
SPZ 160x3	160	164	2	2012	50	-	40	131	-	32	8	-
SPZ 170x3	170	174	3	2012	50	-	40	141	4	32	4	-
SPZ 180x3	180	184	6	2012	50	7	40	151	-	32	8	106
SPZ 190x3	190	194	6	2012	50	10	40	161	4	32	4	112
SPZ 200x3	200	204	6	2012	50	10	40	171	4	32	4	112
SPZ 224x3	224	228	6	2012	50	12	40	195	4	32	4	112
SPZ 250x3	250	254	5	2012	50	-	40	221	4	32	4	112
SPZ 280x3	280	284	4	2517	60	-	40	251	2.5	45	2.5	124
SPZ 315x3	315	319	4	2517	60	-	40	286	2.5	45	2.5	124
SPZ 355x3	355	359	4	2517	60	-	40	326	2.5	45	2.5	124
SPZ 400x3	400	404	4	2517	60	-	40	371	2.5	45	2.5	124
SPZ 450x3	450	454	4	2517	60	-	40	421	2.5	45	2.5	124
SPZ 500x3	500	504	4	2517	60	-	40	471	2.5	45	2.5	124
SPZ 630x3	630	634	4	3020	75	-	40	601	5.5	51	5.5	150
SPZ 800x3	800	804	4	3020	75	-	40	771	5.5	51	5.5	146

V-Belt pulleys for taper bush according to ISO4183 and DIN2211 norms

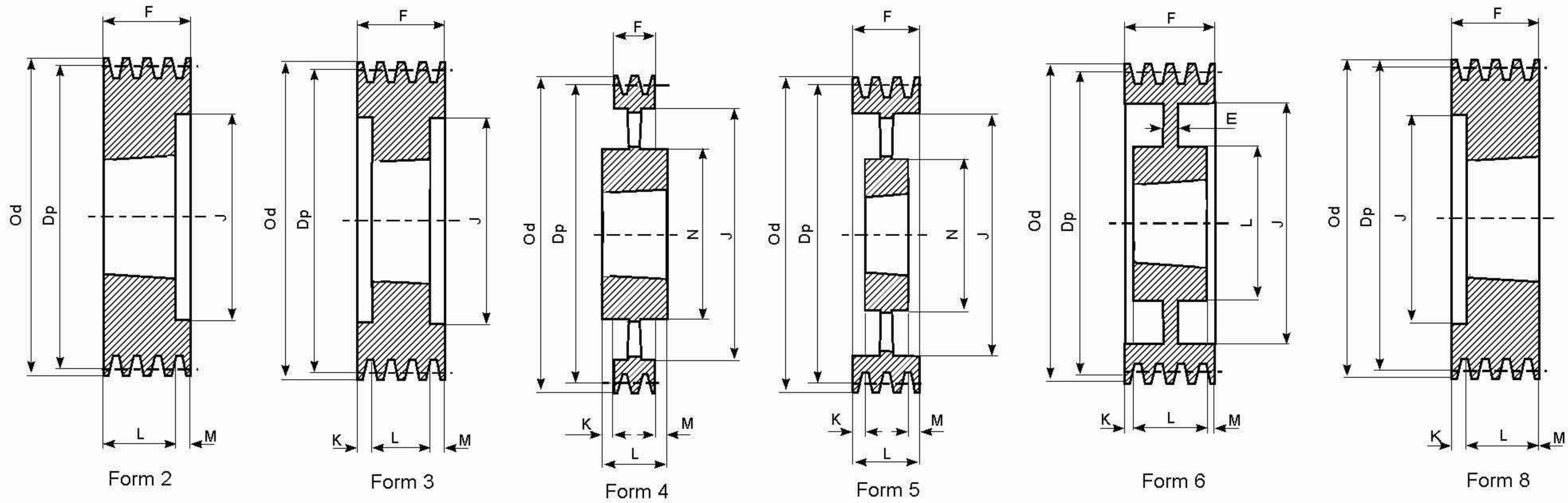

SPZ - 4

Description	Dp.	Od.	Form	Bush No.	Max Bore	E	F	J	K	L	M	N
SPZ 80x4	80	84	8	1210	32	-	52	51	27	25	-	-
SPZ 85x4	85	89	8	1610	42	-	52	60	27	25	-	-
SPZ 90x4	90	94	8	1610	42	-	52	61	27	25	-	-
SPZ 95x4	95	99	2	1610	42	-	52	66	-	25	27	-
SPZ 100x4	100	104	2	1610	42	-	52	71	-	25	27	-
SPZ 106x4	106	110	2	1610	42	-	52	76	-	25	27	-
SPZ 112x4	112	116	2	2012	50	-	52	83	-	32	20	-
SPZ 118x4	118	122	2	2012	50	-	52	90	-	32	20	-
SPZ 125x4	125	129	2	2012	50	-	52	96	-	32	20	-
SPZ 132x4	132	136	2	2012	50	-	52	103	-	32	20	-
SPZ 140x4	140	144	2	2012	50	-	52	111	-	32	20	-
SPZ 150x4	150	154	2	2517	60	-	52	121	-	45	7	-
SPZ 160x4	160	164	2	2517	60	-	52	131	-	45	7	-
SPZ 170x4	170	174	2	2517	60	-	52	141	-	45	7	-
SPZ 180x4	180	184	2	2517	60	-	52	151	-	45	7	-
SPZ 190x4	190	194	3	2517	60	-	52	161	3.5	45	3.5	-
SPZ 200x4	200	204	6	2517	60	8	52	171	3.5	45	3.5	124
SPZ 224x4	224	228	6	2517	60	14	52	195	3.5	45	3.5	124
SPZ 250x4	250	254	6	2517	60	12	52	221	3.5	45	3.5	124
SPZ 280x4	280	284	6	2517	60	14	52	251	3.5	45	3.5	124
SPZ 315x4	315	319	5	2517	60	-	52	286	3.5	45	3.5	124
SPZ 355x4	355	359	5	2517	60	-	52	326	3.5	45	3.5	124
SPZ 400x4	400	404	5	2517	60	-	52	371	3.5	45	3.5	124
SPZ 450x4	450	454	5	3020	75	-	52	421	0.5	51	0.5	146
SPZ 500x4	500	504	5	3020	75	-	52	471	0.5	51	0.5	146
SPZ 630x4	630	634	4	3030	75	-	52	601	12	76	12	146
SPZ 800x4	800	804	4	3030	75	-	52	771	12	76	12	146

V-Belt pulleys for taper bush according to ISO4183 and DIN2211 norms

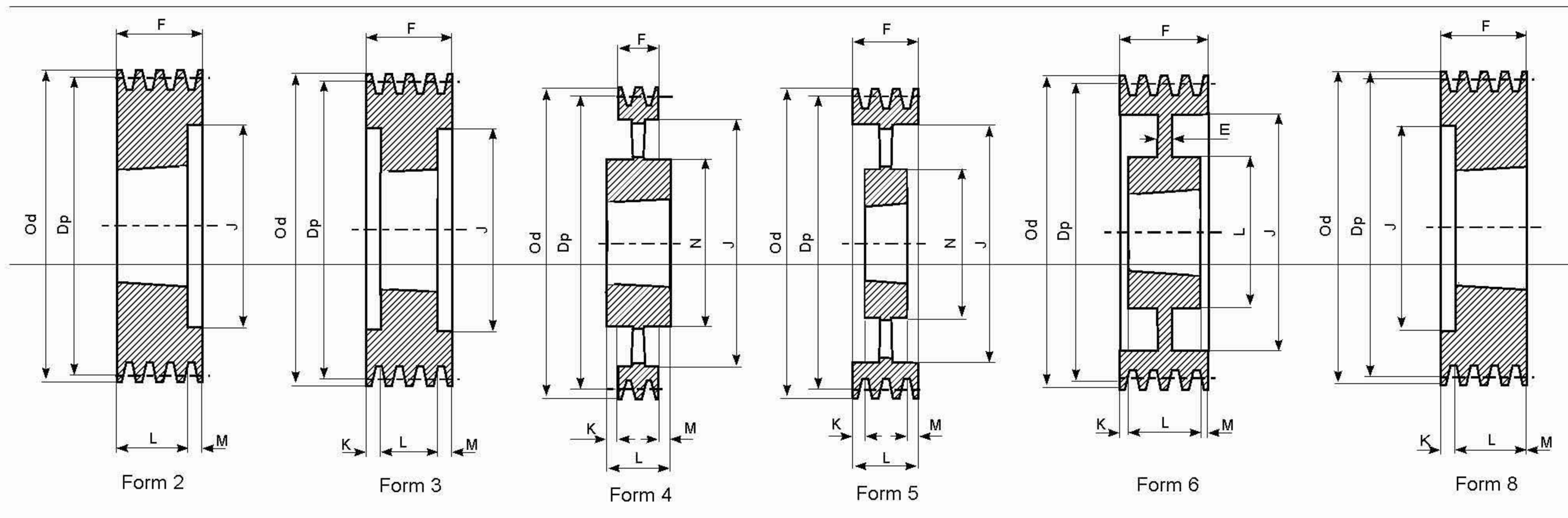

SPZ - 5

Description	Dp.	Od.	Form	Bush No.	Max Bore	E	F	J	K	L	M	N
SPZ 85x5	85	89	8	1610	42	-	64	60	39	25	-	-
SPZ 90x5	90	94	8	1610	42	-	64	61	39	25	-	-
SPZ 95x5	95	99	8	1610	42	-	64	66	39	25	-	-
SPZ 100x5	100	104	8	2012	50	-	64	71	32	32	-	-
SPZ 106x5	106	110	8	2012	50	-	64	76	32	32	-	-
SPZ 112x5	112	116	2	2012	50	-	64	83	-	32	32	-
SPZ 118x5	118	122	2	2012	50	-	64	90	-	32	32	-
SPZ 125x5	125	129	2	2012	50	-	64	96	-	32	32	-
SPZ 132x5	132	136	8	2517	60	-	64	103	19	45	19	-
SPZ 140x5	140	144	2	2517	60	-	64	111	-	45	19	-
SPZ 150x5	150	154	2	2517	60	-	64	121	-	45	19	-
SPZ 160x5	160	164	2	2517	60	-	64	131	-	45	19	-
SPZ 170x5	170	174	2	2517	60	-	64	141	-	45	19	-
SPZ 180x5	180	184	2	2517	60	-	64	151	-	45	19	-
SPZ 190x5	190	194	3	2517	60	-	64	161	9.5	45	9.5	-
SPZ 200x5	200	204	3	2517	60	-	64	171	9.5	45	9.5	-
SPZ 224x5	224	228	6	2517	60	20	64	195	9.5	45	9.5	124
SPZ 250x5	250	254	6	2517	60	16	64	221	9.5	45	9.5	124
SPZ 280x5	280	284	6	2517	60	15	64	251	9.5	45	9.5	124
SPZ 315x5	315	319	5	2517	60	-	64	286	9.5	45	9.5	124
SPZ 355x5	355	359	5	2517	60	-	64	326	9.5	45	9.5	124
SPZ 400x5	400	404	5	3020	75	-	64	371	6.5	51	6.5	146
SPZ 450x5	450	454	5	3020	75	-	64	421	6.5	51	6.5	146
SPZ 500x5	500	504	4	3030	75	-	64	471	6	76	6	146
SPZ 630x5	630	634	4	3030	75	-	64	601	6	76	6	146
SPZ 800x5	800	804	4	3535	90	-	64	771	12.5	89	12.5	178

V-Belt pulleys for taper bush according to ISO4183 and DIN2211 norms

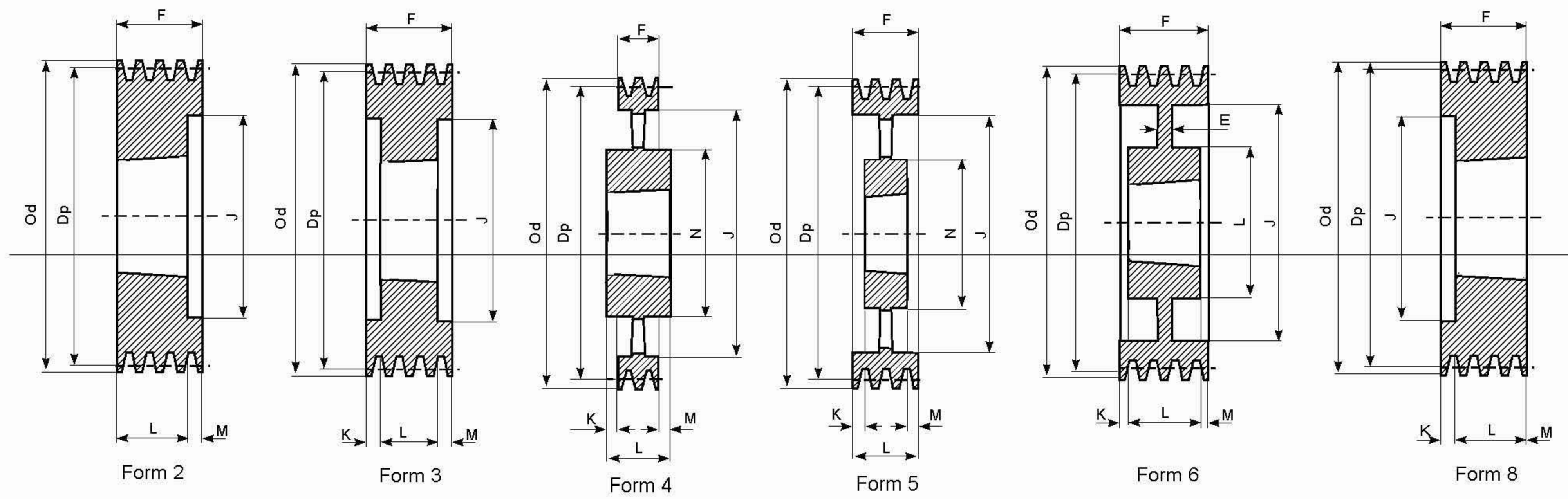

SPZ - 6

Description	Dp.	Od.	Form	Bush No.	Max Bore	E	F	J	K	L	M	N
SPZ 90x6	90	94	8	1610	42	-	76	61	51	25	-	-
SPZ 95x6	95	99	8	1610	42	-	76	66	51	25	-	-
SPZ 100x6	100	104	8	2012	50	-	76	71	44	32	-	-
SPZ 106x6	106	110	8	2012	50	-	76	76	44	32	-	-
SPZ 112x6	112	116	8	2012	50	-	76	83	44	32	-	-
SPZ 118x6	118	122	8	2517	60	-	76	90	31	45	-	-
SPZ 125x6	125	129	8	2517	60	-	76	96	31	45	-	-
SPZ 132x6	132	136	8	2517	60	-	76	103	31	45	-	-
SPZ 140x6	140	144	8	2517	60	-	76	111	-	45	31	-
SPZ 150x6	150	154	8	2517	60	-	76	121	-	45	31	-
SPZ 160x6	160	164	8	2517	60	-	76	131	-	45	31	-
SPZ 170x6	170	174	8	2517	60	-	76	141	-	45	31	-
SPZ 180x6	180	184	3	2517	60	-	76	151	15.5	45	15.5	-
SPZ 190x6	190	194	3	2517	60	-	76	161	15.5	45	15.5	124
SPZ 200x6	200	204	3	2517	60	-	76	171	15.5	45	15.5	124
SPZ 224x6	224	228	6	2517	60	26	76	195	15.5	45	15.5	124
SPZ 250x6	250	254	6	2517	60	26	76	221	15.5	45	15.5	124
SPZ 280x6	280	284	6	2517	60	15	76	251	15.5	45	15.5	124
SPZ 315x6	315	319	6	2517	60	15	76	286	15.5	45	15.5	124
SPZ 355x6	355	359	5	2517	60	-	76	326	15.5	45	15.5	124
SPZ 400x6	400	404	5	3030	75	-	76	371	-	76	-	146
SPZ 450x6	450	454	5	3030	75	-	76	421	-	76	-	146
SPZ 500x6	500	504	5	3030	75	-	76	471	-	76	-	146
SPZ 630x6	630	634	4	3535	90	-	76	601	6.5	89	6.5	175
SPZ 800x6	800	804	4	3535	90	-	76	771	6.5	89	6.5	178

V-Belt pulleys for taper bush according to ISO4183 and DIN2211 norms

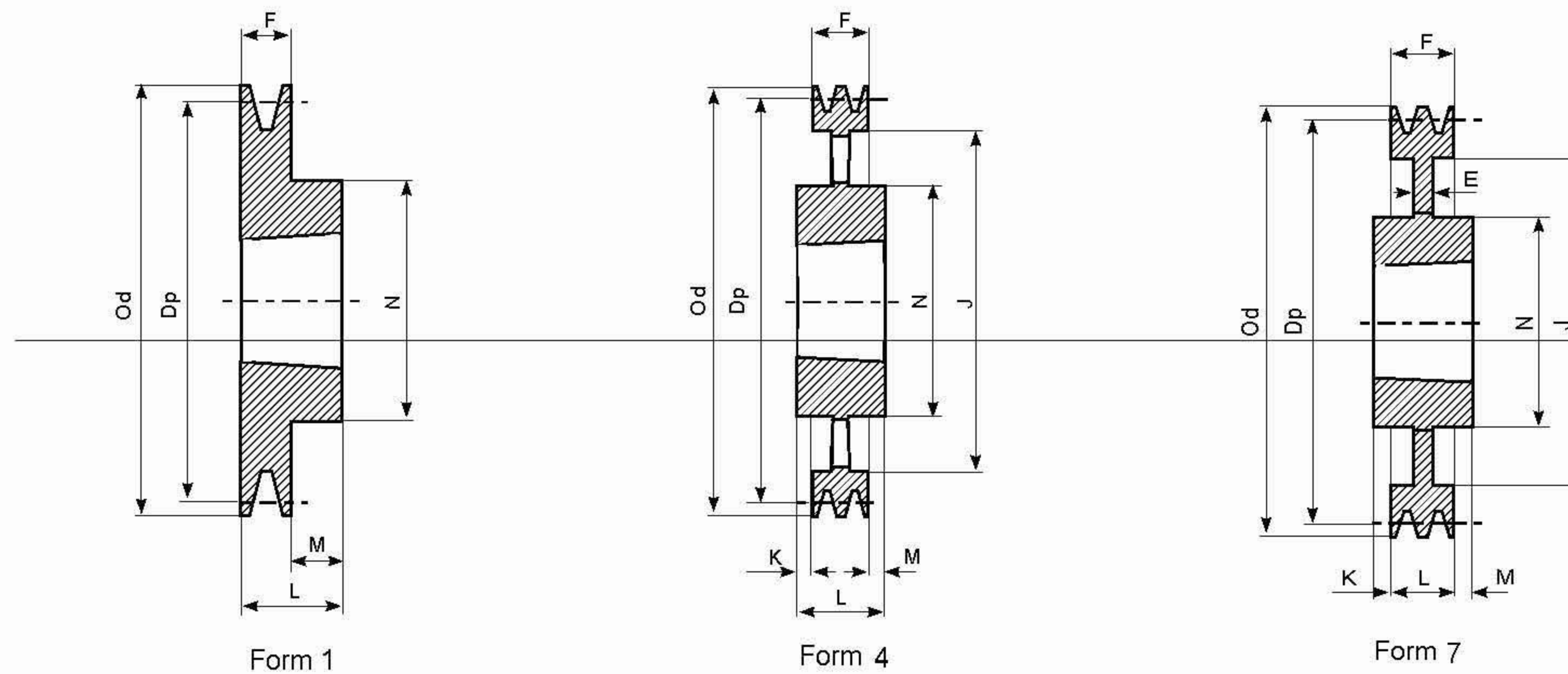

SPA - 1

Description	Dp.	Od.	Form	Bush No.	Max Bore	E	F	J	K	L	M	N
SPA 63 - 01	63	68,5	9	1108	28		40	38	18	22		
SPA 67 - 01	67	72,5	1	1108	28		20	38		22	2	62
SPA 71 - 01	71	76,5	1	1108	28		20			22	2	62
SPA 75 - 01	75	80,5	1	1108	28		20			22	5	62
SPA 80 - 01	80	85,5	1	1210	32		20			25	5	75
SPA 85 - 01	85	90,5	1	1210	32		20			25	5	75
SPA 90 - 01	90	95,5	1	1210	32		20			25	5	75
SPA 95 - 01	95	100,5	1	1210	32		20			25	5	75
SPA 100 - 01	100	105,5	1	1610	42		20			25	5	80
SPA 106 - 01	106	111,5	1	1610	42		20			25	5	80
SPA 112 - 01	112	117,5	1	1610	42		20			25	5	80
SPA 118 - 01	118	123,5	1	1610	42		20			25	5	80
SPA 125 - 01	125	130,5	1	1610	42		20			25	5	80
SPA 132 - 01	132	137,5	1	1610	42		20			25	5	80
SPA 140 - 01	140	145,5	1	1610	42		20			25	5	80
SPA 150 - 01	150	155,5	1	1610	42		20			25	5	80
SPA 160 - 01	160	165,5	1	1610	42		20			25	5	80
SPA 170 - 01	170	175,5	1	1610	42		20			25	5	80
SPA 180 - 01	180	185,5	1	1610	42		20			25	5	80
SPA 190 - 01	190	195,5	1	1610	42		20			25	5	80
SPA 200 - 01	200	205,5	7	2012	50	10	20	165		32	12	100
SPA 224 - 01	224	229,5	7	2012	50	10	20	189		32	12	100
SPA 250 - 01	250	255,5	7	2012	50	10	20	215	6	32	6	100
SPA 280 - 01	280	285,5	7	2012	50	10	20	245		32	12	100
SPA 315 - 01	315	320,5	4	2012	50		20	280		32	12	100
SPA 355 - 01	355	360,5	4	2012	50		20	320		32	12	100
SPA 400 - 01	400	405,5	4	2012	50		20	365		32	12	100
SPA 450 - 01	450	455,5	4	2012	50		20	415		32	12	100
SPA 500 - 01	500	505,5	4	2517	60		20	465		45	25	120
SPA 630 - 01	630	635,5	4	2517	60		20	595		45	25	120

V-Belt pulleys for taper bush according to ISO4183 and DIN2211 norms

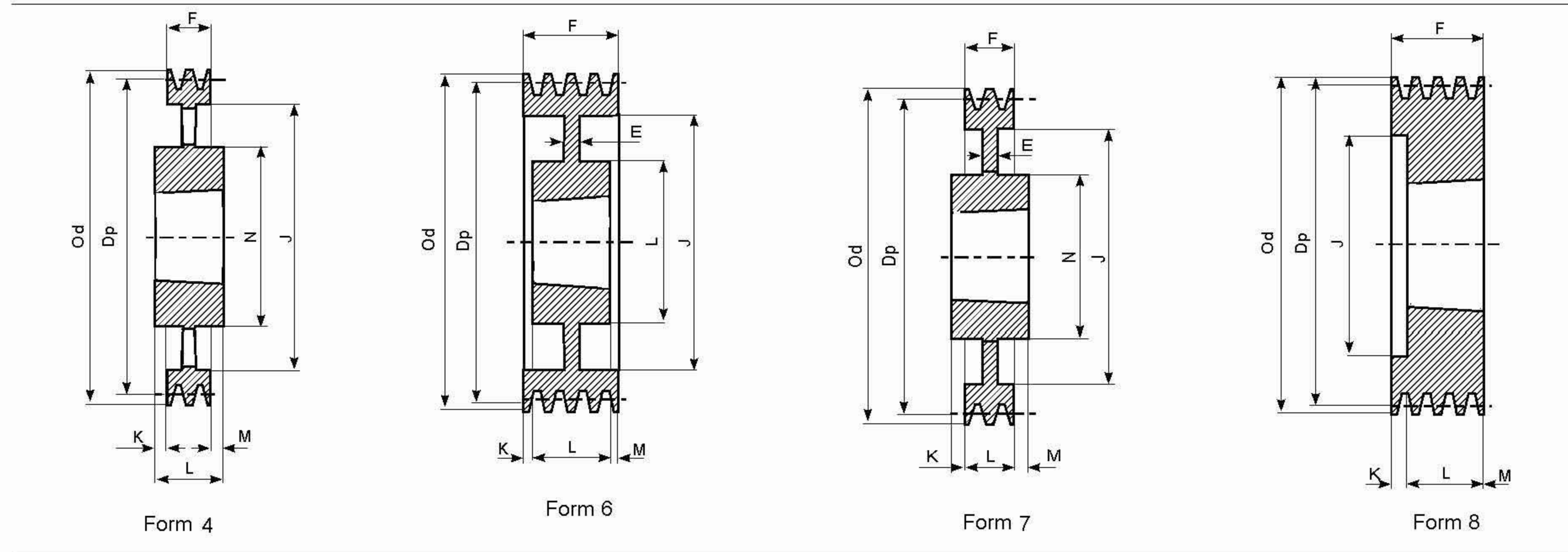

SPA - 2

Description	Dp.	Od.	Form	Bush No.	Max Bore	E	F	J	K	L	M	N
SPA 63x2	63	68,5	8	1008	28	-	35	32,5	13	22	-	-
SPA 67x2	67	72,5	8	1108	28	-	35	37	13	22	-	-
SPA 71x2	71	76,5	8	1108	28	-	35	40	13	22	-	-
SPA 75x2	75	80,5	8	1108	28	-	35	44	13	25	-	-
SPA 80x2	80	85,5	8	1210	32	-	35	50	10	25	-	-
SPA 85x2	85	90,5	8	1210	32	-	35	55	10	25	-	-
SPA 90x2	90	95,5	8	1610	42	-	35	59	10	25	-	-
SPA 95x2	95	100,5	8	1610	42	-	35	63	10	25	-	-
SPA 100x2	100	105,5	2	1610	42	-	35	66	-	25	10	-
SPA 106x2	106	111,5	2	1610	42	-	35	72	-	25	10	-
SPA 112x2	112	117,5	2	1610	42	-	35	78	-	25	10	-
SPA 118x2	118	123,5	2	1610	42	-	35	84	-	25	10	-
SPA 125x2	125	130,5	2	1610	42	-	35	91	-	25	10	-
SPA 132x2	132	137,5	8	2012	50	-	35	98	3	32	-	-
SPA 140x2	140	145,5	8	2012	50	-	35	106	3	32	-	-
SPA 150x2	150	155,5	8	2012	50	-	35	116	3	32	-	-
SPA 160x2	160	165,5	8	2012	50	-	35	125	3	32	-	-
SPA 170x2	170	175,5	8	2012	50	-	35	135	3	32	-	-
SPA 180x2	180	185,5	6	2012	50	10	35	146	1,5	32	1,5	108
SPA 190x2	190	195,5	6	2012	50	6	35	156	-	32	3	108
SPA 200x2	200	205,5	7	2517	60	10	35	165	5	45	5	123
SPA 212x2	212	217,5	7	2517	60	18	35	177	5	45	5	123
SPA 224x2	224	229,5	7	2517	60	18	35	189	-	45	10	124
SPA 236x2	236	241,5	7	2517	60	12	35	202	-	45	10	124
SPA 250x2	250	255,5	7	2517	60	12	35	215	5	45	5	124
SPA 280x2	280	285,5	7	2517	60	12	35	245	-	45	10	124
SPA 315x2	315	320,5	7	2517	60	12	35	280	-	45	10	124
SPA 355x2	355	360,5	4	2517	60	-	35	320	-	45	10	124
SPA 400x2	400	405,5	4	2517	60	-	35	365	-	45	10	124
SPA 450x2	450	455,5	4	2517	60	-	35	465	-	45	10	124
SPA 500x2	500	505,5	4	2517	60	-	35	525	-	45	10	125
SPA 630x2	630	635,5	4	3020	75	-	35	595	8	51	18	159

V-Belt pulleys for taper bush according to ISO4183 and DIN2211 norms

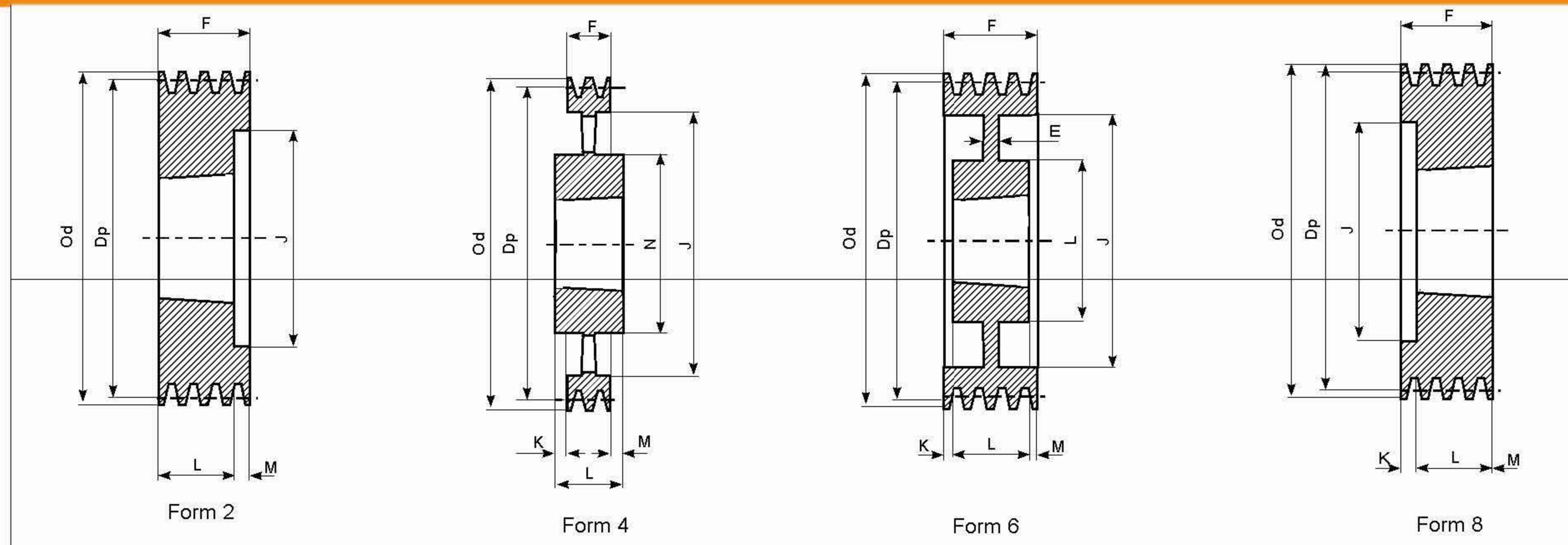

SPA - 3

Description	Dp.	Od.	Form	Bush No.	Max Bore	E	F	J	K	L	M	N
SPA 71x3	71	76,5	8	1108	28	-	50	40	28	22	-	-
SPA 75x3	75	80,5	8	1108	28	-	50	44	28	22	-	-
SPA 80x3	80	85,5	8	1210	32	-	50	50	25	25	-	-
SPA 85x2	85	90,5	8	1210	32	-	50	55	25	25	-	-
SPA 90x3	90	95,5	8	1610	42	-	50	59	25	25	-	-
SPA 95x3	95	100,5	8	1610	42	-	50	63	25	25	-	-
SPA 100x3	100	105,5	2	1610	42	-	50	66	-	25	25	-
SPA 106x3	106	111,5	2	1610	42	-	50	72	-	25	25	-
SPA 112x3	112	117,5	8	2012	50	-	50	78	18	32	-	-
SPA 118x3	118	123,5	2	2012	50	-	50	84	-	32	18	-
SPA 125x3	125	130,5	2	2012	50	-	50	91	-	32	18	-
SPA 132x3	132	137,5	2	2012	50	-	50	98	-	32	18	-
SPA 140x3	140	145,5	2	2517	60	-	50	106	-	45	5	-
SPA 150x3	150	155,5	2	2517	60	-	50	116	-	45	5	-
SPA 160x3	160	165,5	2	2517	60	-	50	125	-	45	5	-
SPA 170x3	170	175,5	2	2517	60	-	50	135	-	45	5	-
SPA 180x3	180	185,5	2	2517	60	-	50	146	-	45	5	-
SPA 190x3	190	195,5	2	2517	60	-	50	156	-	45	5	-
SPA 200x3	200	205,5	6	2517	60	20	50	165	2,5	45	2,5	123
SPA 212x3	212	217,5	6	2517	60	20	50	177	2,5	45	2,5	123
SPA 224x3	224	229,5	6	2517	60	20	50	189	2,5	45	2,5	124
SPA 236x3	236	241,5	6	2517	60	20	50	202	2,5	45	2,5	124
SPA 250x3	250	255,5	6	2517	60	20	50	215	2,5	45	2,5	124
SPA 280x3	280	285,5	6	2517	60	20	50	245	2,5	45	2,5	124
SPA 315x3	315	320,5	4	3020	75	25	50	280	0,5	51	0,5	159
SPA 355x3	355	360,5	4	3020	75	-	50	320	0,5	51	0,5	159
SPA 400x3	400	405,5	4	3020	75	-	50	365	-	51	1	159
SPA 450x3	450	455,5	4	3020	75	-	50	415	-	51	1	159
SPA 500x3	500	505,5	4	3020	75	-	50	465	-	51	1	159
SPA 560x3	560	565,5	4	3020	75	-	50	525	-	51	1	150
SPA 630x3	630	635,5	4	3020	75	-	50	595	-	51	1	150
SPA 800x3	800	805,5	4	3535	90	-	50	765	19,05	89	19,05	175
SPA 1000x3	1000	1005,5	4	3535	90	-	50	965	19,05	89	19,05	175

V-Belt pulleys for taper bush according to ISO4183 and DIN2211 norms

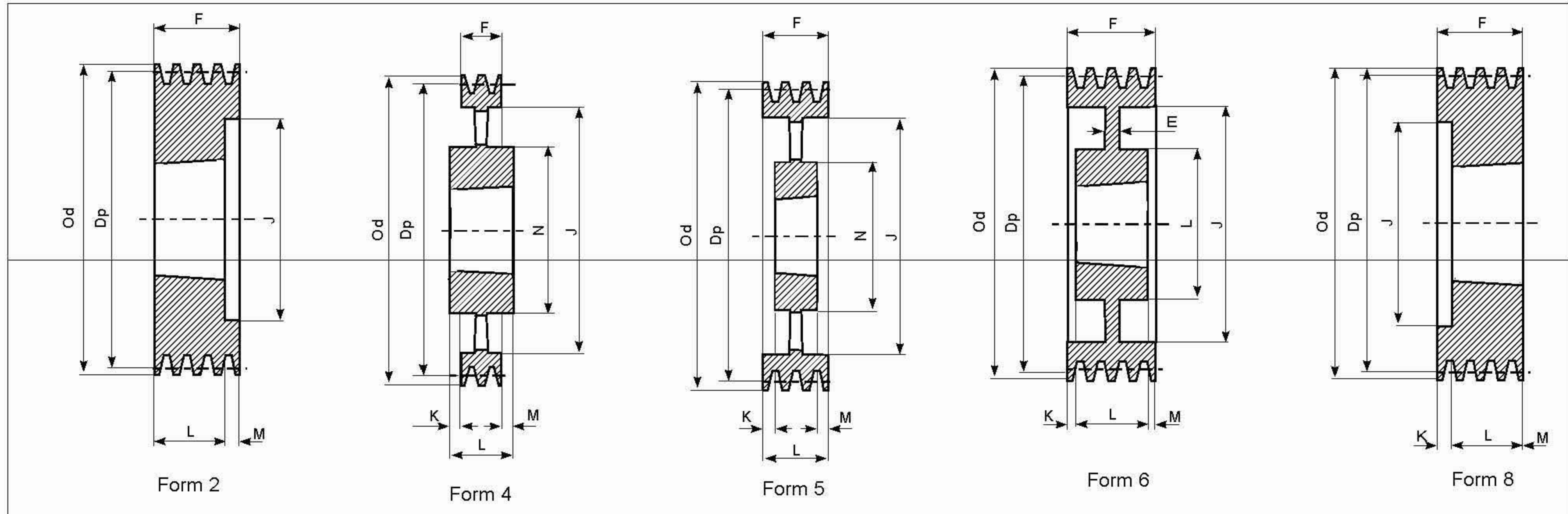

SPA - 4

Description	Dp.	Od.	Form	Bush No.	Max Bore	E	F	J	K	L	M	N
SPA 95x4	95	100,5	8	1615	42	-	65	63	27	38	-	-
SPA 100x4	100	105,5	2	1615	42	-	65	66	-	38	27	-
SPA 106x4	106	111,5	8	2012	50	-	65	72	33	32	-	-
SPA 112x4	112	117,5	8	2012	50	-	65	78	33	32	-	-
SPA 118x4	118	123,5	2	2012	50	-	65	84	-	32	33	-
SPA 125x4	125	130,5	2	2012	50	-	65	91	-	32	33	-
SPA 132x4	132	137,5	2	2517	60	-	65	98	-	45	20	-
SPA 140x4	140	145,5	2	2517	60	-	65	106	-	45	20	-
SPA 150x4	150	155,5	2	2517	60	-	65	116	-	45	20	-
SPA 160x4	160	165,5	2	2517	60	-	65	125	-	45	20	-
SPA 170x4	170	175,5	2	2517	60	-	65	135	-	45	20	-
SPA 180x4	180	185,5	2	2517	60	-	65	146	-	45	20	-
SPA 190x4	190	195,5	2	2517	60	-	65	156	-	45	20	-
SPA 200x4	200	205,5	2	3020	75	-	65	165	-	51	14	-
SPA 212x4	212	217,5	2	3020	75	-	65	177	-	51	14	-
SPA 224x4	224	229,5	2	3020	75	-	65	189	-	51	14	-
SPA 236x4	236	241,5	6	3020	75	25	65	202	-	51	14	-
SPA 250x4	250	255,5	6	3020	75	20	65	215	7	51	7	159
SPA 280x4	280	285,5	6	3020	75	25	65	245	7	51	7	159
SPA 315x4	315	320,5	6	3020	75	25	65	280	7	51	7	159
SPA 355x4	355	360,5	5	3020	75	-	65	320	7	51	7	159
SPA 400x4	400	405,5	5	3020	75	-	65	365	7	51	7	159
SPA 450x4	450	455,5	5	3020	75	-	65	415	7	51	7	159
SPA 500x4	500	505,5	5	3020	75	-	65	465	7	51	7	159
SPA 560x4	560	565,5	4	3535	90	-	65	525	12	89	12	175
SPA 630x4	630	635,5	4	3535	90	-	65	595	12	89	12	175
SPA 800x4	800	805,5	4	3535	90	-	65	765	12	89	12	175
SPA 1000x4	1000	1005,5	4	4040	100	-	65	965	18.5	102	18.5	210

V-Belt pulleys for taper bush according to ISO4183 and DIN2211 norms

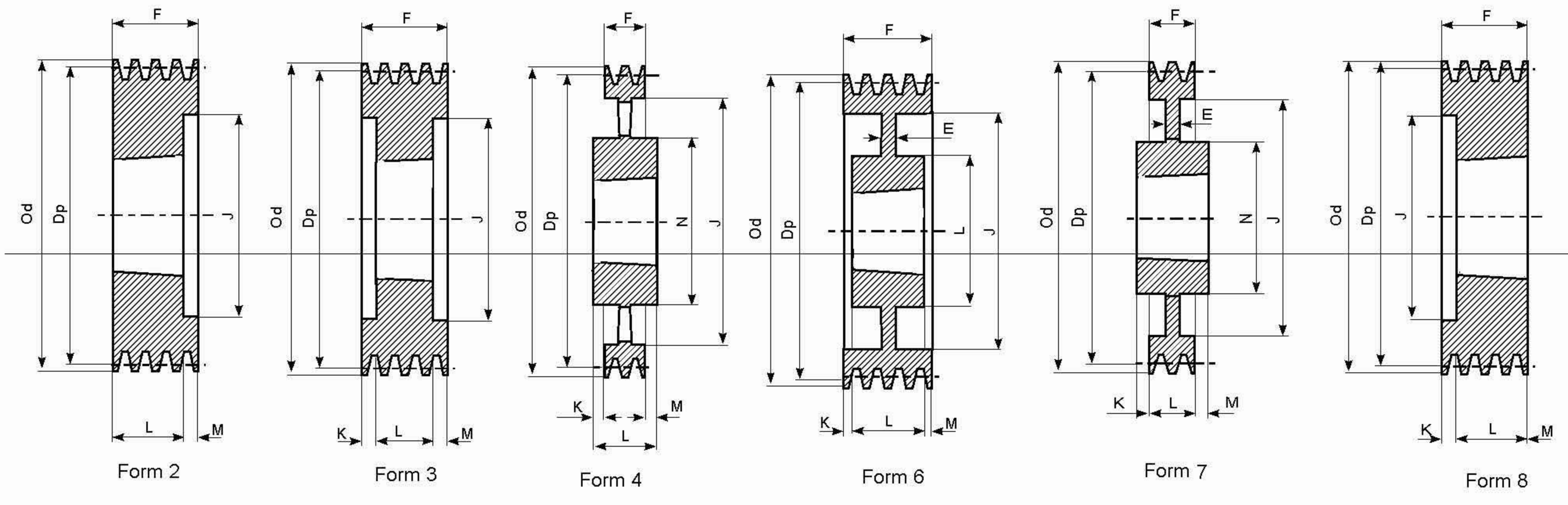

SPA - 5

Description	Dp.	Od.	Form	Bush No.	Max Bore	E	F	J	K	L	M	N
SPA 100x5	100	105,5	2	1615	42	-	80	66	-	38	42	-
SPA 106x5	106	111,5	8	2012	50	-	80	72	48	32	-	-
SPA 112x5	112	117,5	8	2012	50	-	80	78	48	32	-	-
SPA 118x5	118	123,5	2	2012	50	-	80	84	-	32	48	-
SPA 125x5	125	130,5	3	2012	50	-	80	91	24	32	24	-
SPA 132x5	132	137,5	3	2517	60	-	80	98	17,5	45	17,5	-
SPA 140x5	140	145,5	3	2517	60	-	80	106	17,5	45	17,5	-
SPA 150x5	150	155,5	3	2517	60	-	80	116	17,5	45	17,5	-
SPA 160x5	160	165,5	3	2517	60	-	80	125	17,5	45	17,5	-
SPA 170x5	170	175,5	3	2517	60	-	80	135	17,5	45	17,5	-
SPA 180x5	180	185,5	2	3020	75	-	80	146	-	51	29	-
SPA 190x5	190	195,5	3	3020	75	-	80	156	14,5	51	14,5	-
SPA 200x5	200	205,5	2	3020	75	-	80	165	14,5	51	14,5	-
SPA 212x5	212	217,5	2	3020	75	-	80	177	-	51	29	-
SPA 224x5	224	229,5	2	3020	75	-	80	189	-	51	29	-
SPA 236x5	236	241,5	6	3020	75	-	80	202	-	51	29	-
SPA 250x5	250	255,5	7	3020	75	20	80	215	14,5	51	14,5	159
SPA 280x5	280	285,5	7	3535	90	25	80	245	4,5	89	4,5	175
SPA 315x5	315	320,5	4	3535	90	25	80	280	4,5	89	4,5	175
SPA 355x5	355	360,5	4	3535	90	-	80	320	4,5	89	4,5	175
SPA 400x5	400	405,5	4	3535	90	-	80	365	4,5	89	4,5	175
SPA 450x5	450	455,5	4	3535	90	-	80	415	4,5	89	4,5	175
SPA 500x5	500	505,5	4	3535	90	-	80	465	4,5	89	4,5	175
SPA 560x5	560	565,5	4	3535	90	-	80	525	4,5	89	4,5	175
SPA 630x5	630	635,5	4	3535	90	-	80	595	4,5	89	4,5	175
SPA 800x5	800	805,5	4	4040	100	-	80	765	11	102	11	210
SPA 1000x5	1000	1005,5	4	4545	110	-	80	965	17	114	17	242

V-Belt pulleys for taper bush according to ISO4183 and DIN2211 norms

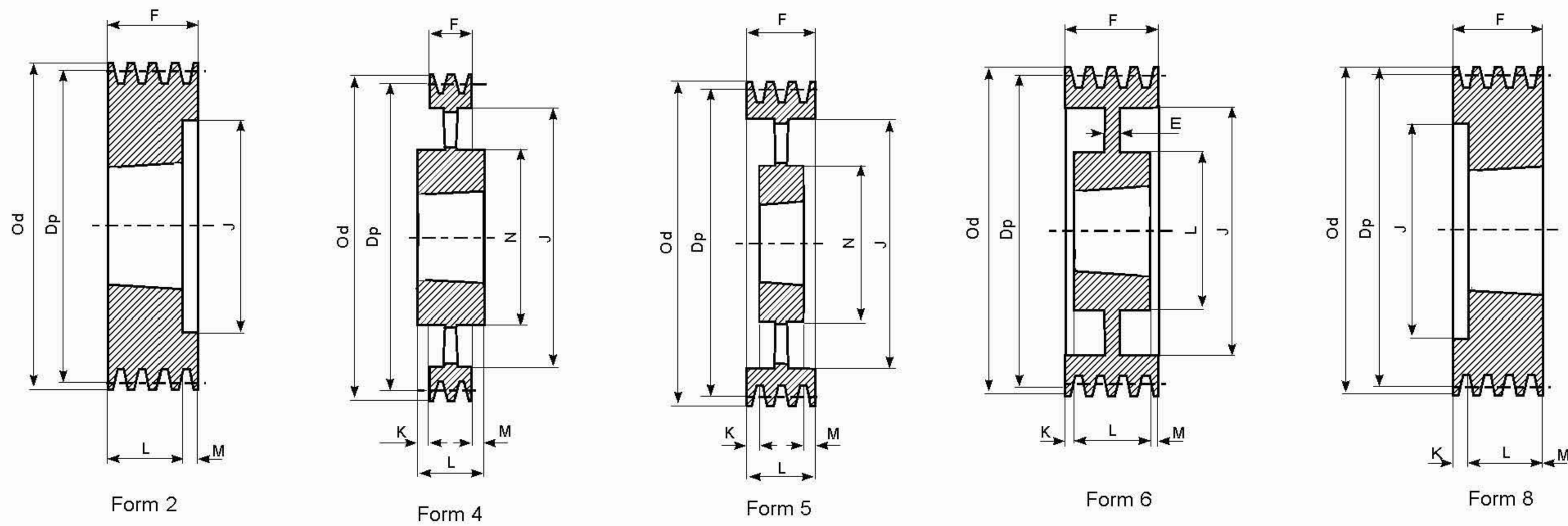

SPA - 6

Description	Dp.	Od.	Form	Bush No.	Max Bore	E	F	J	K	L	M	N
SPA 100x6	100	105,5	3	1610	42	-	95	66	30	25	40	-
SPA 106x6	106	111,5	8	2012	50	-	95	72	63	32	-	-
SPA 112x6	112	117,5	8	2012	50	-	95	78	63	32	-	-
SPA 118x6	118	123,5	8	2012	50	-	95	84	63	32	-	-
SPA 125x6	125	130,5	3	2012	50	-	95	91	31,5	32	31,5	-
SPA 132x6	132	137,5	3	2517	60	-	95	98	25	45	25	-
SPA 140x6	140	145,5	3	2517	60	-	95	106	25	45	25	-
SPA 150x6	150	155,5	3	2517	60	-	95	116	25	45	25	-
SPA 160x6	160	165,5	3	2517	60	-	95	125	25	45	25	-
SPA 180x6	180	185,5	3	3020	75	-	95	146	22	51	22	-
SPA 200x6	200	205,5	3	3020	75	-	95	165	22	51	22	-
SPA 224x6	224	229,5	3	3020	75	-	95	189	22	51	22	-
SPA 236x6	236	241,5	3	3020	75	-	95	202	22	51	22	-
SPA 250x6	250	255,5	6	3020	75	20	95	215	22	51	22	155
SPA 280x6	280	285,5	6	3535	90	25	95	245	3	89	3	175
SPA 315x6	315	320,5	6	3535	90	25	95	280	3	89	3	175
SPA 355x6	355	360,5	5	3535	90	-	95	320	3	89	3	175
SPA 400x6	400	405,5	5	3535	90	-	95	365	3	89	3	175
SPA 450x6	450	455,5	5	3535	90	-	95	415	3	89	3	175
SPA 500x6	500	505,5	5	3535	90	-	95	465	3	89	3	175
SPA 560x6	560	565,5	5	3535	90	-	95	525	3	89	3	175
SPA 630x6	630	635,5	4	4040	100	-	95	595	3,5	102	3,5	210
SPA 800x6	800	805,5	4	4040	100	-	95	765	3,5	102	3,5	210
SPA 1000x6	1000	1005,5	4	4040	110	-	95	965	9,5	114	9,5	242

V-Belt pulleys for taper bush according to ISO4183 and DIN2211 norms

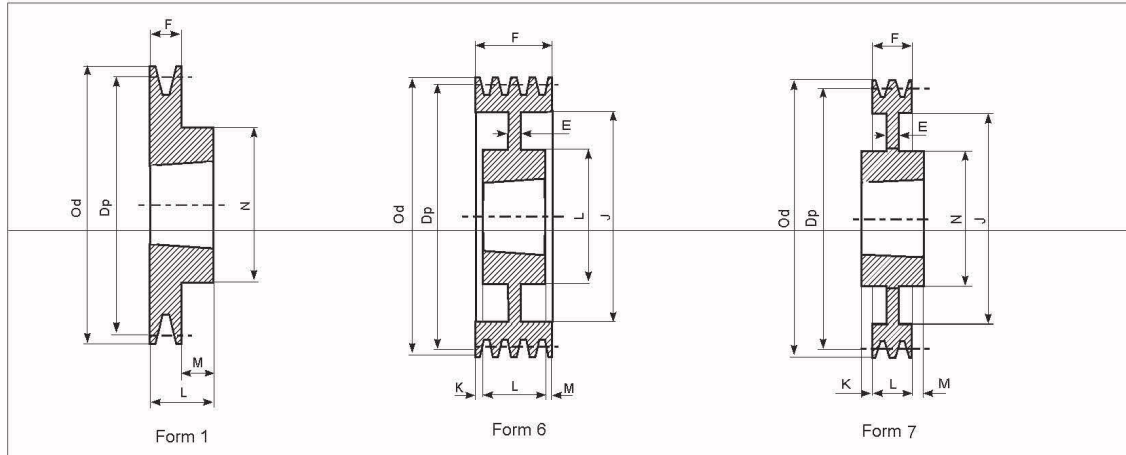

SPB - 1

Description	Dp.	Od.	Form	Bush No.	Max Bore	E	F	J	K	L	M	N
SPB 90x1	90	97	1	1610	42	-	25	-	-	25	-	-
SPB 100x1	100	107	1	1610	42	-	25	-	-	25	-	-
SPB 106x1	106	113	1	1610	42	-	25	-	-	25	-	-
SPB 112x1	112	119	1	1610	42	-	25	-	-	25	-	-
SPB 118x1	118	125	1	1610	42	-	25	-	-	25	-	-
SPB 125x1	125	132	1	1610	42	-	25	-	-	25	-	-
SPB 132x1	132	139	1	1610	42	-	25	-	-	25	-	-
SPB 140x1	140	147	1	1610	42	-	25	-	-	25	-	-
SPB 150x1	150	157	1	1610	42	-	25	-	-	25	-	-
SPB 160x1	160	167	1	1610	42	-	25	-	-	25	-	-
SPB 170x1	170	177	1	1610	42	-	25	-	-	25	-	-
SPB 180x1	180	187	6	1610	42	15	25	132	-	25	-	90
SPB 190x1	190	197	7	2012	50	15	25	147	3,5	32	3,5	104
SPB 200x1	200	207	7	2012	50	15	25	157	3,5	32	3,5	104
SPB 212x1	212	219	7	2012	50	15	25	169	3,5	32	3,5	104
SPB 224x1	224	231	7	2012	50	15	25	181	3,5	32	3,5	104
SPB 236x1	236	243	7	2012	50	15	25	193	3,5	32	3,5	104
SPB 250x1	250	257	7	2012	50	20	25	207	3,5	32	3,5	104
SPB 280x1	280	287	7	2012	50	20	25	237	3,5	32	3,5	104
SPB 300x1	300	307	7	2012	50	20	25	257	3,5	32	3,5	104
SPB 315x1	315	322	7	2012	50	20	25	272	3,5	32	3,5	104

V-Belt pulleys for taper bush according to ISO4183 and DIN2211 norms

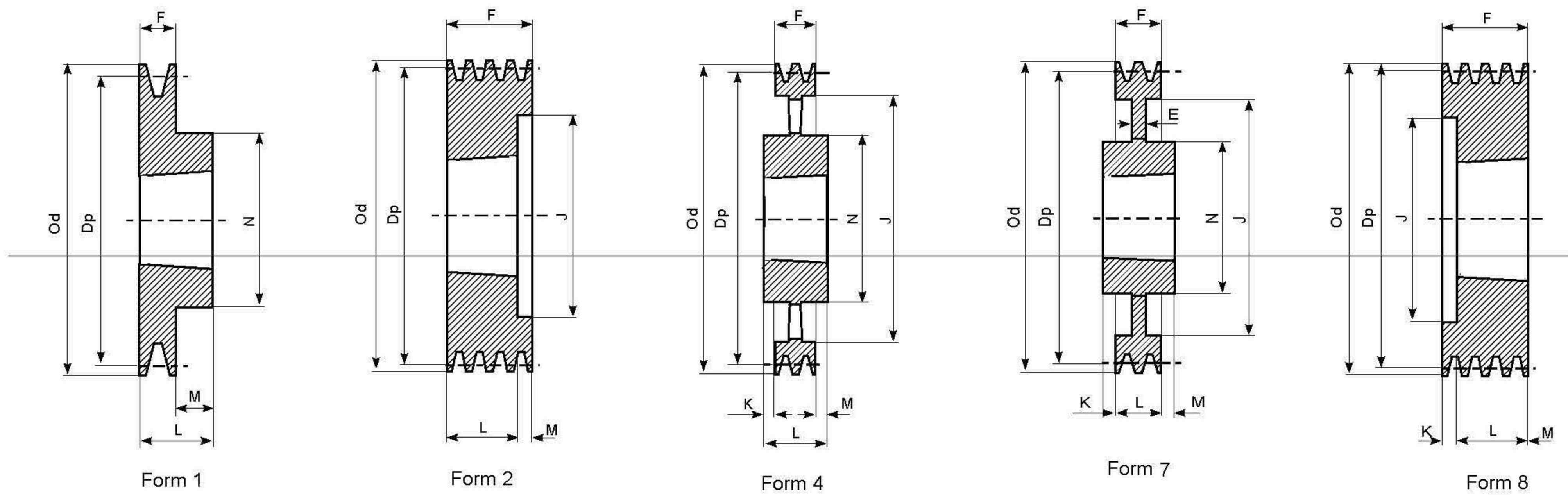

SPB - 2

Description	Dp.	Od.	Form	Bush No.	Max Bore	E	F	J	K	L	M	N
SPB 100x2	100	107	8	1610	42	-	44	62	19	25	-	-
SPB 106x2	106	113	2	1610	42	-	44	67	-	25	19	-
SPB 112x2	112	119	2	1610	42	-	44	72	-	25	19	-
SPB 118x2	118	125	2	1610	42	-	44	78	-	25	19	-
SPB 125x2	125	132	2	2012	50	-	44	82	-	32	12	-
SPB 132x2	132	139	2	2012	50	-	44	89	-	32	12	-
SPB 140x2	140	147	2	2012	50	-	44	97	-	32	12	-
SPB 150x2	150	157	2	2012	50	-	44	107	-	32	12	-
SPB 160x2	160	167	2	2012	50	-	44	117	-	32	12	-
SPB 170x2	170	177	2	2012	50	-	44	127	-	32	12	-
SPB 180x2	180	187	1	2517	60	-	44	-	-	45	1	120
SPB 190x2	190	197	1	2517	60	-	44	-	-	45	1	120
SPB 200x2	200	207	1	2517	60	-	44	-	-	45	1	117
SPB 212x2	212	219	7	2517	60	20	44	169	-	45	1	117
SPB 224x2	224	231	7	2517	60	15	44	181	-	45	1	117
SPB 236x2	236	243	7	2517	60	15	44	193	-	45	1	117
SPB 250x2	250	257	7	2517	60	20	44	207	-	45	1	125
SPB 280x2	280	287	7	2517	60	20	44	237	-	45	1	125
SPB 300x2	300	307	7	2517	60	20	44	257	-	45	1	125
SPB 315x2	315	322	7	2517	60	20	44	272	-	45	1	125
SPB 335x2	335	342	7	2517	60	20	44	292	-	45	1	125
SPB 355x2	355	362	7	3020	75	15	44	312	3,5	51	3,5	144
SPB 400x2	400	407	4	3020	75	-	44	357	3,5	51	3,5	150
SPB 450x2	450	457	4	3020	75	-	44	407	3,5	51	3,5	150
SPB 500x2	500	507	4	3020	75	-	44	457	3,5	51	3,5	150
SPB 560x2	560	567	4	3030	75	-	44	517	4	76	28	150
SPB 630x2	630	637	4	3030	75	-	44	587	16	76	16	150

V-Belt pulleys for taper bush according to ISO4183 and DIN2211 norms

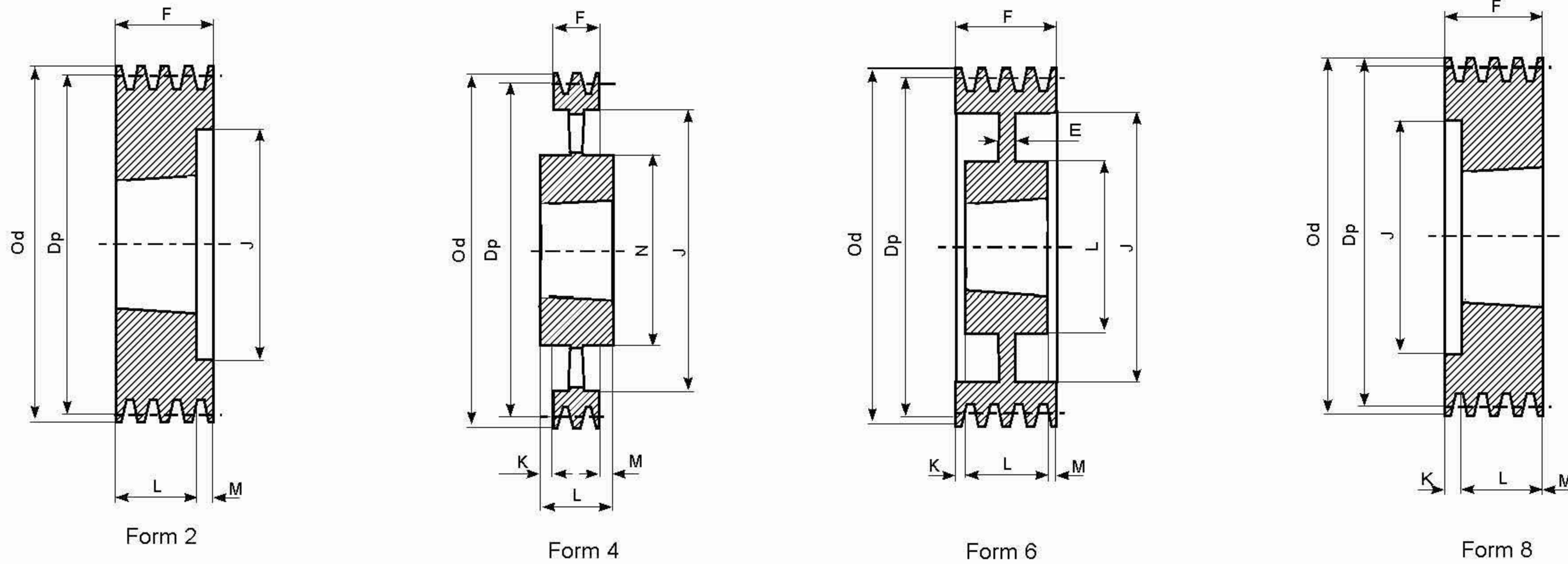

SPB - 3

Description	Dp.	Od.	Form	Bush No.	Max Bore	E	F	J	K	L	M	N
SPB 100x3	100	107	2	1610	42	-	63	62	38	25	-	-
SPB 106x3	106	113	2	1610	42	-	63	67	-	25	38	-
SPB 112x3	112	119	2	1610	42	-	63	72	-	25	38	-
SPB 118x3	118	125	2	1610	42	-	63	78	-	25	38	-
SPB 125x3	125	132	2	2012	50	-	63	82	-	32	31	-
SPB 132x3	132	139	2	2012	50	-	63	89	-	32	31	-
SPB 140x3	140	147	2	2012	50	-	63	97	-	32	31	-
SPB 150x3	150	157	2	2517	60	-	63	107	-	45	18	-
SPB 160x3	160	167	2	2517	60	-	63	117	-	45	18	-
SPB 170x3	170	177	2	2517	60	-	63	127	-	45	18	-
SPB 180x3	180	187	2	2517	60	-	63	137	-	45	18	-
SPB 190x3	190	197	2	2517	60	-	63	147	-	45	18	-
SPB 200x3	200	207	2	2517	60	-	63	157	-	45	18	-
SPB 212x3	212	219	6	2517	60	15	63	169	-	45	18	117
SPB 224x3	224	231	6	2517	60	15	63	181	-	45	18	117
SPB 236x3	236	243	6	2517	60	15	63	193	-	45	18	117
SPB 250x3	250	257	6	3020	75	20	63	207	-	51	12	144
SPB 280x3	280	287	6	3020	75	20	63	237	6	51	6	144
SPB 300x3	300	307	6	3020	75	20	63	257	6	51	6	144
SPB 315x3	315	322	6	3020	75	20	63	272	6	51	6	144
SPB 335x3	335	342	6	3020	75	20	63	292	6	51	6	144
SPB 355x3	355	362	6	3020	75	15	63	312	6	51	6	144
SPB 400x3	400	407	4	3535	90	-	63	357	13	89	13	175
SPB 450x3	450	457	4	3535	90	-	63	407	-	89	26	175
SPB 500x3	500	507	4	3535	90	-	63	457	-	89	26	175
SPB 560x3	560	567	4	3535	90	-	63	517	-	89	26	175
SPB 630x3	630	637	4	3535	90	-	63	587	-	89	26	175
SPB 710x3	710	717	4	3535	90	-	63	664	13	89	13	175
SPB 800x3	800	807	4	3535	90	-	63	754	13	89	13	175
SPB 900x3	900	907	4	3535	90	-	63	854	13	89	13	175
SPB 1000x3	1000	1007	4	4040	100	-	63	954	19,5	102	19,5	210
SPB 1250x3	1250	1257	4	4040	100	-	63	1204	19,5	102	19,5	210

V-Belt pulleys for taper bush according to ISO4183 and DIN2211 norms

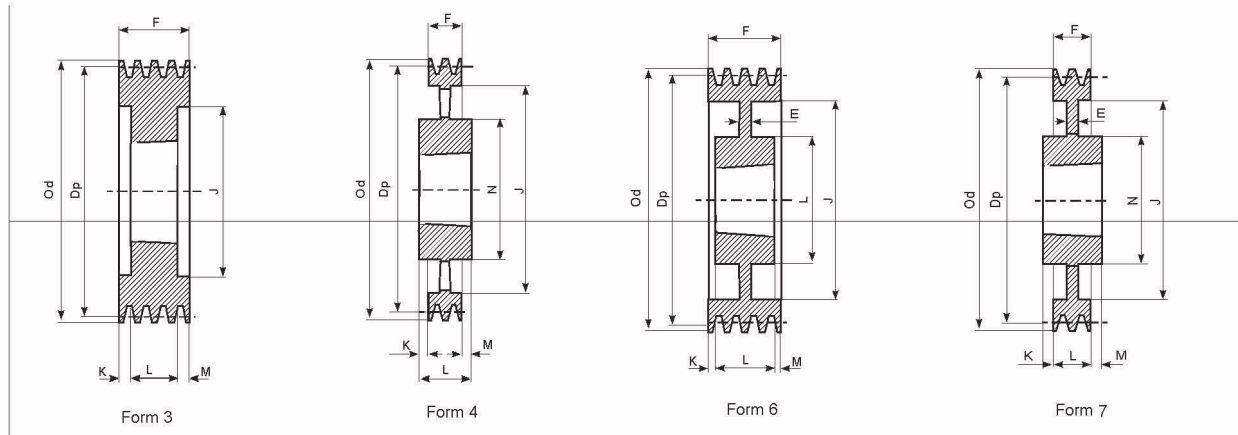

SPB - 4

Description	Dp.	Od.	Form	Bush No.	Max Bore	E	F	J	K	L	M	N
SPB 125x4	125	132	3	2012	50	-	82	82	25	32	25	-
SPB 132x4	132	139	3	2012	50	-	82	89	25	32	25	-
SPB 140x4	140	147	3	2517	60	-	82	100	18,5	45	18,5	-
SPB 150x4	150	157	3	2517	60	-	82	107	18,5	45	18,5	-
SPB 160x4	160	167	3	2517	60	-	82	117	18,5	45	18,5	-
SPB 170x4	170	177	3	2517	60	-	82	127	18,5	45	18,5	-
SPB 180x4	180	187	3	2517	60	-	82	137	18,5	45	18,5	-
SPB 190x4	190	197	3	2517	60	-	82	147	18,5	45	18,5	-
SPB 200x4	200	207	3	3020	75	-	82	157	15,5	51	15,5	-
SPB 212x4	212	219	3	3020	75	-	82	169	15,5	51	15,5	-
SPB 224x4	224	231	3	3020	75	-	82	181	15,5	51	15,5	-
SPB 236x4	236	243	3	3020	75	-	82	193	15,5	51	15,5	-
SPB 250x4	250	257	6	3020	75	25	82	207	15,5	51	15,5	144
SPB 280x4	280	287	6	3020	75	25	82	237	15,5	51	15,5	144
SPB 300x4	300	307	7	3535	90	25	82	257	-	89	7	175
SPB 315x4	315	322	7	3535	90	25	82	272	3,5	89	3,5	175
SPB 335x4	335	342	7	3535	90	25	82	292	3,5	89	3,5	175
SPB 355x4	355	362	7	3535	90	25	82	312	3,5	89	3,5	175
SPB 400x4	400	407	4	3535	90	-	82	357	3,5	89	3,5	175
SPB 450x4	450	457	4	3535	90	-	82	407	-	89	7	175
SPB 500x4	500	507	4	3535	90	-	82	457	-	89	7	175
SPB 560x4	560	567	4	3535	90	-	82	517	-	89	7	175
SPB 630x4	630	637	4	3535	90	-	82	587	-	89	7	175
SPB 710x4	710	717	4	3535	90	-	82	664	3,5	89	3,5	175
SPB 800x4	800	807	4	4040	100	-	82	754	10	102	10	210
SPB 900x4	900	907	4	4040	100	-	82	854	10	102	10	210
SPB 1000x4	1000	1007	4	4040	100	-	82	954	10	102	10	210
SPB 1250x4	1250	1257	4	4545	100	-	82	1204	16	114	16	210

V-Belt pulleys for taper bush according to ISO4183 and DIN2211 norms

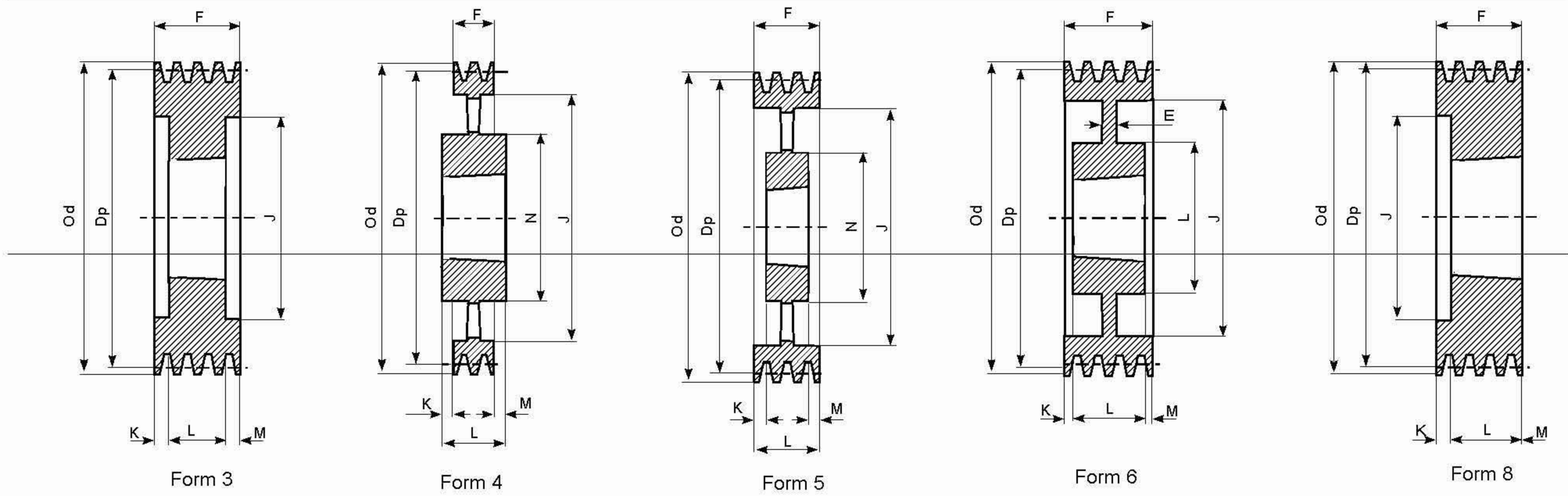

SPB - 5

Description	Dp.	Od.	Form	Bush No.	Max Bore	E	F	J	K	L	M	N
SPB 125x5	125	132	8	2012	50	-	101	87	69	32	-	-
SPB 132x5	132	139	8	2517	60	-	101	94	56	45	-	-
SPB 140x5	140	147	3	2517	60	-	101	97	28	45	28	-
SPB 150x5	150	157	3	2517	60	-	101	107	28	45	28	-
SPB 160x5	160	167	3	2517	60	-	101	117	28	45	28	-
SPB 170x5	170	177	3	3020	75	-	101	127	25	51	25	-
SPB 180x5	180	187	3	3020	75	-	101	137	25	51	25	-
SPB 190x5	190	197	3	3020	75	-	101	147	25	51	25	-
SPB 200x5	200	207	3	3020	75	-	101	157	25	51	25	-
SPB 212x5	212	219	3	3020	75	-	101	169	25	51	25	-
SPB 224x5	224	231	3	3020	75	-	101	181	25	51	25	-
SPB 236x5	236	243	3	3535	90	-	101	193	6	89	6	-
SPB 250x5	250	257	3	3535	90	-	101	207	6	89	6	-
SPB 280x5	280	287	6	3535	90	25	101	237	6	89	6	175
SPB 300x5	300	307	6	3535	90	25	101	257	6	89	6	175
SPB 315x5	315	322	6	3535	90	25	101	272	6	89	6	175
SPB 335x5	335	342	6	3535	90	25	101	292	6	89	6	175
SPB 355x5	355	362	6	3535	90	17	101	312	6	89	6	175
SPB 400x5	400	407	5	3535	90	-	101	357	6	89	6	175
SPB 450x5	450	457	5	3535	90	-	101	407	-	89	12	175
SPB 500x5	500	507	5	3535	90	-	101	457	-	89	12	175
SPB 560x5	560	567	4	4040	100	-	101	517	-	102	1	210
SPB 630x5	630	637	4	4040	100	-	101	587	-	102	1	210
SPB 710x5	710	717	4	4040	100	-	101	664	-	102	1	210
SPB 800x5	800	807	4	4040	100	-	101	754	-	102	1	210
SPB 900x5	900	907	4	4040	100	-	101	854	-	102	1	210
SPB 1000x5	1000	1007	4	4545	110	-	101	954	6.5	114	6.5	242
SPB 1250x5	1250	1257	4	4545	110	-	101	1204	6.5	114	6.5	242

V-Belt pulleys for taper bush according to ISO4183 and DIN2211 norms

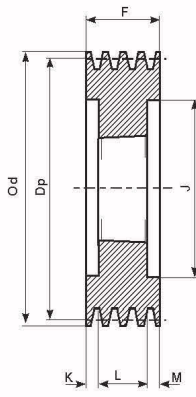

Form 3

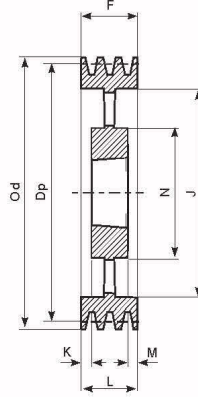

Form 5

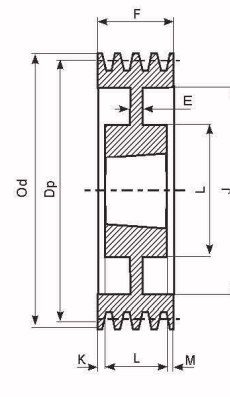

Form 6

SPB - 6

Description	Dp.	Od.	Form	Bush No.	Max Bore	E	F	J	K	L	M	N
SPB 140x6	140	147	3	2517	60	-	120	100	37,5	45	37,5	-
SPB 150x6	150	157	3	2517	60	-	120	107	37,5	45	37,5	-
SPB 160x6	160	167	3	3020	75	-	120	117	34,5	51	34,5	-
SPB 170x6	170	177	3	3020	75	-	120	127	34,5	51	34,5	-
SPB 180x6	180	187	3	3020	75	-	120	137	34,5	51	34,5	-
SPB 190x6	190	197	3	3020	75	-	120	147	34,5	51	34,5	-
SPB 200x6	200	207	3	3020	75	-	120	157	34,5	51	34,5	-
SPB 212x6	212	219	3	3535	90	-	120	169	15,5	89	15,5	-
SPB 224x6	224	231	3	3535	90	-	120	181	15,5	89	15,5	-
SPB 236x6	236	243	3	3535	90	-	120	193	15,5	89	15,5	-
SPB 250x6	250	257	3	3535	90	-	120	207	15,5	89	15,5	-
SPB 280x6	280	287	6	3535	90	25	120	237	15,5	89	15,5	175
SPB 300x6	300	307	6	3535	90	25	120	257	15,5	89	15,5	175
SPB 315x6	315	322	6	3535	90	25	120	272	15,5	89	15,5	175
SPB 335x6	335	342	6	3535	90	25	120	292	15,5	89	15,5	175
SPB 355x6	355	362	6	3535	90	25	120	312	15,5	89	15,5	175
SPB 400x6	400	407	5	3535	90	-	120	357	15,5	89	15,5	175
SPB 450x6	450	457	5	4040	100	-	120	407	-	102	18	210
SPB 500x6	500	507	5	4040	100	-	120	457	-	102	18	210
SPB 560x6	560	567	5	4040	100	-	120	517	-	102	18	210
SPB 630x6	630	637	5	4040	100	-	120	587	-	102	18	210
SPB 710x6	710	717	5	4040	100	-	120	664	9	102	9	210
SPB 800x6	800	807	5	4545	110	-	120	754	3	114	3	242
SPB 900x6	900	907	5	4545	110	-	120	854	3	114	3	242
SPB 1000x6	1000	1007	5	4545	110	-	120	954	3	114	3	242
SPB 1250x6	1250	1257	5	4545	110	-	120	1204	3	114	3	242

V-Belt pulleys for taper bush according to ISO4183 and DIN2211 norms

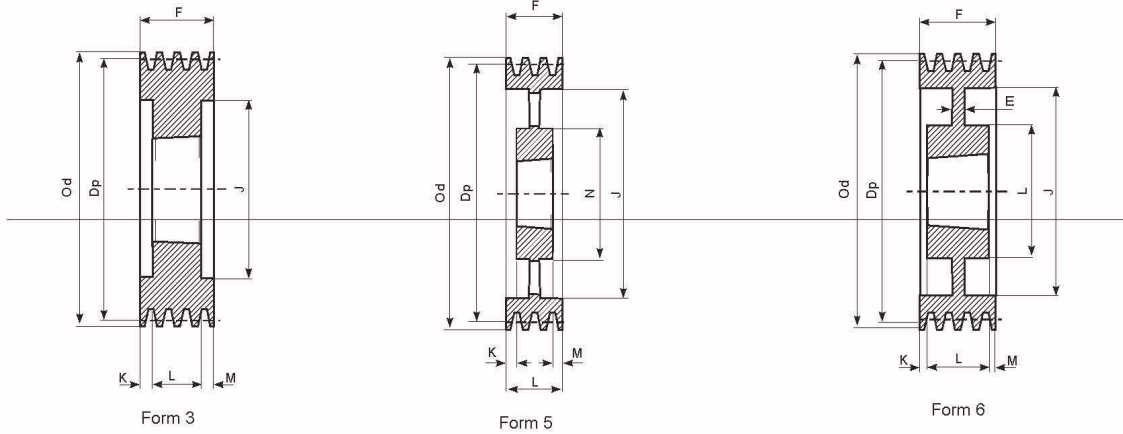

SPB - 8

Description	Dp.	Od.	Form	Bush No.	Max Bore	E	F	J	K	L	M	N
SPB 140x8	140	147	3	2517	60	-	158	97	37,5	45	37,5	-
SPB 160x8	160	167	3	3020	75	-	158	117	53,5	51	53,5	-
SPB 170x8	170	177	3	3030	75	-	158	127	41	76	41	-
SPB 180x8	180	187	3	3030	75	-	158	137	41	76	41	-
SPB 190x8	190	197	3	3030	75	-	158	147	41	76	41	-
SPB 200x8	200	207	3	3535	90	-	158	157	34,5	89	34,5	-
SPB 212x8	212	219	3	3535	90	-	158	169	34,5	89	34,5	-
SPB 224x8	224	231	3	3535	90	-	158	181	34,5	89	34,5	-
SPB 236x8	236	243	3	3535	90	-	158	193	34,5	89	34,5	-
SPB 250x8	250	257	3	3535	90	-	158	207	34,5	89	34,5	-
SPB 280x8	280	287	6	3535	90	25	158	237	34,5	89	34,5	175
SPB 300x8	300	307	6	3535	90	25	158	257	34,5	89	34,5	175
SPB 315x8	315	322	6	3535	90	25	158	272	34,5	89	34,5	175
SPB 335x8	335	342	6	3535	90	25	158	292	34,5	89	34,5	175
SPB 355x8	355	362	6	3535	90	25	158	312	34,5	89	34,5	175
SPB 400x8	400	407	6	4040	100	30	158	357	28	102	28	210
SPB 450x8	450	457	5	4040	100	-	158	407	28	102	28	210
SPB 500x8	500	507	5	4040	100	-	158	457	28	102	28	210
SPB 560x8	560	567	5	4545	110	-	158	517	22	114	22	242
SPB 630x8	630	637	5	4545	110	-	158	587	22	114	22	242
SPB 710x8	710	717	5	4545	110	-	158	664	22	114	22	242
SPB 800x8	800	807	5	4545	110	-	158	754	22	114	22	242
SPB 900x8	900	907	5	4545	110	-	158	854	22	114	22	242
SPB 1000x8	1000	1007	5	5050	110	-	158	954	15,5	127	15,5	267
SPB 1250x8	1250	1257	5	5050	110	-	158	1204	15,5	127	15,5	267

V-Belt pulleys for taper bush according to ISO4183 and DIN2211 norms

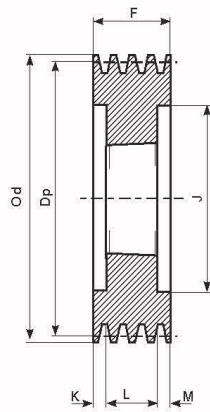

Form 3

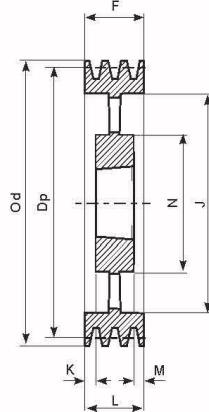

Form 5

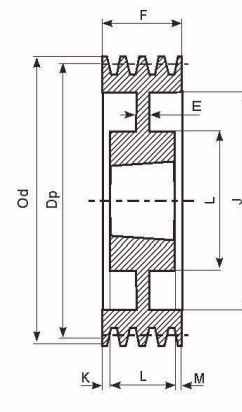

Form 6

SPB - 10

Description	Dp.	Od.	Form	Bush No.	Max Bore	E	F	J	K	L	M	N
SPB 224x10	224	231	3	3535	90	-	196	181	53,5	89	53,5	-
SPB 236x10	236	243	3	3535	90	-	196	193	53,5	89	53,5	-
SPB 250x10	250	257	3	3535	90	-	196	207	53,5	89	53,5	-
SPB 280x10	280	287	6	3535	90	30	196	237	53,5	89	53,5	175
SPB 315x10	315	322	6	3535	90	30	196	272	53,5	89	53,5	175
SPB 335x10	335	342	6	4040	100	30	196	292	47	102	47	210
SPB 355x10	355	362	6	4040	100	30	196	312	47	102	47	210
SPB 400x10	400	407	6	4040	100	30	196	357	47	102	47	210
SPB 450x10	450	457	5	4545	110	-	196	407	41	114	41	242
SPB 500x10	500	507	5	4545	110	-	196	457	41	114	41	242
SPB 560x10	560	567	5	4545	110	-	196	517	41	114	41	242
SPB 630x10	630	637	5	4545	110	-	196	587	41	114	41	242
SPB 710x10	710	717	5	4545	110	-	196	664	41	114	41	242
SPB 800x10	800	807	5	4545	110	-	196	754	41	114	41	242
SPB 900x10	900	907	5	5050	125	-	196	854	34,5	127	34,5	267
SPB 1000x10	1000	1007	5	5050	125	-	196	954	34,5	127	34,5	267
SPB 1250X10	1250	1257	5	5050	125	-	196	1204	34,5	127	34,5	267

V-Belt pulleys for taper bush according to ISO4183 and DIN2211 norms

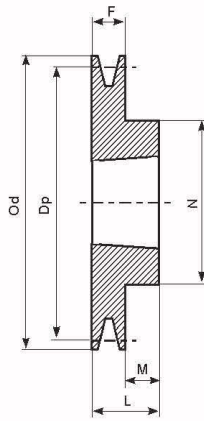

Form 1

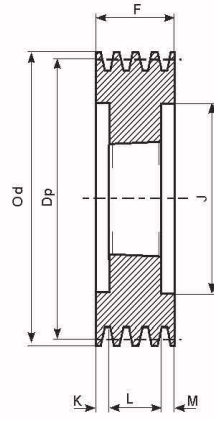

Form 3

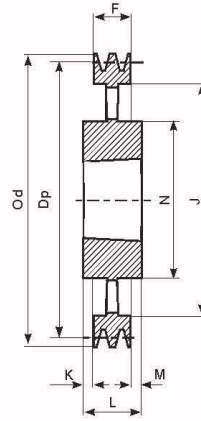

Form 4

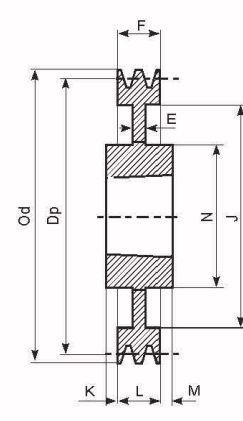

Form 7

SPC - 3

Description	Dp.	Od.	Form	Bush No.	Max Bore	E	F	J	K	L	M	N
SPC 200x3	200	209,6	3	2517	60	-	85	144	20	45	20	-
SPC 212x3	212	221,6	3	3020	75	-	85	156	17	51	17	-
SPC 224x3	224	233,6	3	3020	75	-	85	168	17	51	17	-
SPC 236x3	236	245,6	3	3020	75	-	85	180	17	51	17	-
SPC 250x3	250	259,6	3	3020	75	-	85	194	17	51	17	-
SPC 265x3	265	274,6	1	3535	90	-	85	209	-	89	4	175
SPC 280x3	280	289,6	1	3535	90	-	85	224	-	89	4	175
SPC 300x3	300	309,6	7	3535	90	20	85	244	2	89	2	175
SPC 315x3	315	324,6	7	3535	90	20	85	259	2	89	2	175
SPC 335x3	335	344,6	7	3535	90	20	85	279	2	89	2	175
SPC 355x3	355	364,6	7	3535	90	20	85	299	2	89	2	175
SPC 375x3	375	384,6	7	3535	90	25	85	319	2	89	2	175
SPC 400x3	400	409,6	7	3535	90	17	85	344	2	89	2	175
SPC 425x3	425	434,6	7	3535	90	17	85	369	2	89	2	175
SPC 450x3	450	459,6	4	3535	90	-	85	394	2	89	2	175
SPC 475x3	475	484,6	4	3535	90	-	85	419	2	89	2	175
SPC 500x3	500	509,6	4	3535	90	-	85	444	2	89	2	175
SPC 530x3	530	539,6	4	3535	90	-	85	474	2	89	2	175
SPC 560x3	560	569,6	4	3535	90	-	85	504	2	89	2	175
SPC 630x3	630	639,6	4	4040	100	-	85	574	8,5	102	8,5	210
SPC 800x3	800	809,6	4	4545	110	-	85	737	14,5	114	14,5	242
SPC 1000x3	1000	1009,6	4	5050	125	-	85	937	21	127	21	267
SPC 1250x3	1250	1259,6	4	5050	125	-	85	1187	21	127	21	267

V-Belt pulleys for taper bush according to ISO4183 and DIN2211 norms

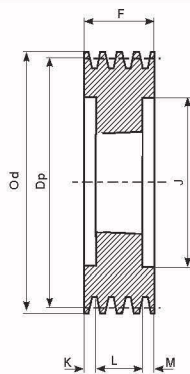

Form 3

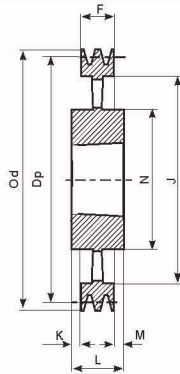

Form 4

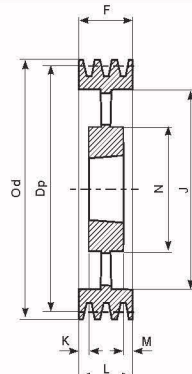

Form 5

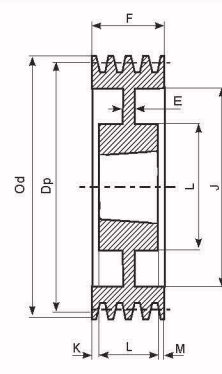

Form 6

SPC - 4

Description	Dp.	Od.	Form	Bush No.	Max Bore	E	F	J	K	L	M	N
SPC 200x4	200	209,6	3	3020	75	-	111	144	30	51	30	-
SPC 212x4	212	221,6	3	3020	75	-	111	156	30	51	30	-
SPC 224x4	224	233,6	3	3535	90	-	111	168	11	89	11	-
SPC 236x4	236	245,6	3	3535	90	-	111	180	11	89	11	-
SPC 250x4	250	259,6	3	3535	90	-	111	194	11	89	11	-
SPC 265x4	265	274,6	3	3535	90	-	111	209	11	89	11	-
SPC 280x4	280	289,6	6	3535	90	18	111	224	11	89	11	175
SPC 300x4	300	309,6	6	3535	90	20	111	244	11	89	11	175
SPC 315x4	315	324,6	6	3535	90	20	111	259	11	89	11	175
SPC 335x4	335	344,6	6	3535	90	20	111	279	11	89	11	175
SPC 355x4	355	364,6	6	3535	90	20	111	299	11	89	11	175
SPC 375x4	375	384,6	6	3535	90	25	111	319	11	89	11	175
SPC 400x4	400	409,6	6	3535	90	18	111	344	11	89	11	175
SPC 425x4	425	434,6	6	3535	90	18	111	369	11	89	11	175
SPC 450x4	450	459,6	5	3535	90	-	111	394	11	89	11	175
SPC 475x4	475	484,6	5	3535	90	-	111	419	11	89	11	175
SPC 500x4	500	509,6	5	3535	90	-	111	444	11	89	11	175
SPC 530x4	530	539,6	5	4040	100	-	111	474	4,5	102	4,5	210
SPC 560x4	560	569,6	5	4040	100	-	111	504	4,5	102	4,5	210
SPC 630x4	630	639,6	4	4545	110	-	111	574	1,5	114	1,5	242
SPC 710x4	710	719,6	4	5050	125	-	111	654	8	127	8	267
SPC 800x4	800	809,6	4	5050	125	-	111	737	8	127	8	267
SPC 1000x4	1000	1009,6	4	5050	125	-	111	937	8	127	8	267
SPC 1250x4	1250	1259,6	4	5050	125	-	111	1187	8	127	8	267

V-Belt pulleys for taper bush according to ISO4183 and DIN2211 norms

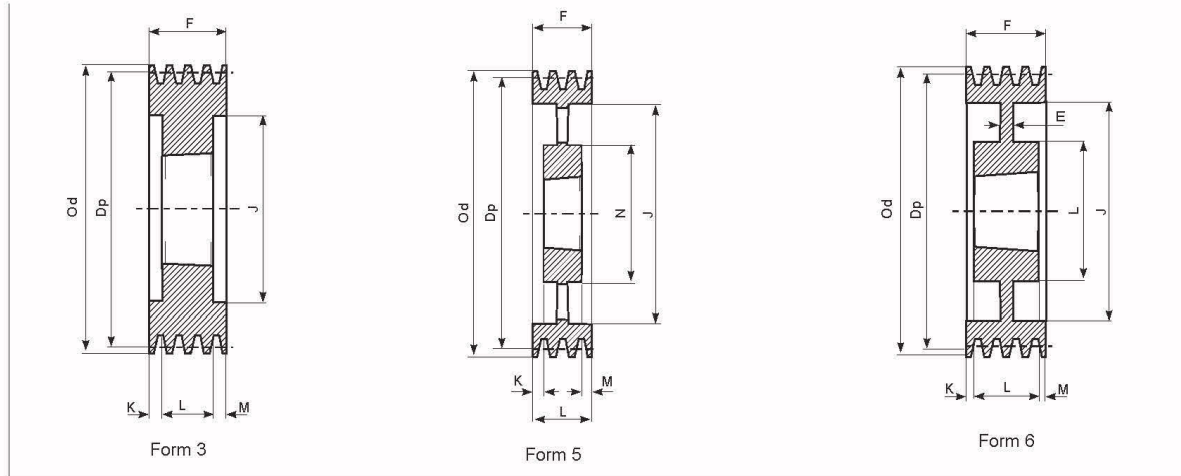

SPC - 5

Description	Dp.	Od.	Form	Bush No.	Max Bore	E	F	J	K	L	M	N
SPC 200x5	200	209,6	3	3535	90	-	136	144	23,5	89	23,5	-
SPC 212x5	212	221,6	3	3535	90	-	136	156	23,5	89	23,5	-
SPC 224x5	224	233,6	3	3535	90	-	136	168	23,5	89	23,5	-
SPC 236x5	236	245,6	3	3535	90	-	136	180	23,5	89	23,5	-
SPC 250x5	250	259,6	3	3535	90	-	136	194	23,5	89	23,5	-
SPC 265x5	265	274,6	3	3535	90	-	136	209	23,5	89	23,5	-
SPC 280x5	280	289,6	3	3535	90	-	136	224	23,5	89	23,5	-
SPC 300x5	300	309,6	6	3535	90	20	136	244	23,5	89	23,5	175
SPC 315x5	315	324,6	6	3535	90	20	136	259	23,5	89	23,5	175
SPC 335x5	335	344,6	6	3535	90	20	136	279	23,5	89	23,5	175
SPC 355x5	355	364,6	6	3535	90	20	136	299	23,5	89	23,5	175
SPC 375x5	375	384,6	6	3535	90	25	136	319	23,5	89	23,5	175
SPC 400x5	400	409,6	6	3535	90	15	136	344	23,5	89	23,5	175
SPC 425x5	425	434,6	6	3535	90	20	136	369	23,5	89	23,5	175
SPC 450x5	450	459,6	5	4040	100	-	136	394	17	102	17	210
SPC 475x5	475	484,6	5	4040	100	-	136	419	17	102	17	210
SPC 500x5	500	509,6	5	4040	100	-	136	444	17	102	17	210
SPC 530x5	530	539,6	5	4545	110	-	136	474	11	114	11	240
SPC 560x5	560	569,6	5	4545	110	-	136	504	11	114	11	242
SPC 630x5	630	639,6	5	5050	125	-	136	574	4,5	127	4,5	267
SPC 710x5	710	719,6	5	5050	125	-	136	654	4,5	127	4,5	267
SPC 800x5	800	809,6	5	5050	125	-	136	737	4,5	127	4,5	267
SPC 1000x5	1000	1009,6	5	5050	125	-	136	937	4,5	127	4,5	267
SPC 1250x5	1250	1259,6	5	5050	125	-	136	1187	4,5	127	4,5	267

V-Belt pulleys for taper bush according to ISO4183 and DIN2211 norms

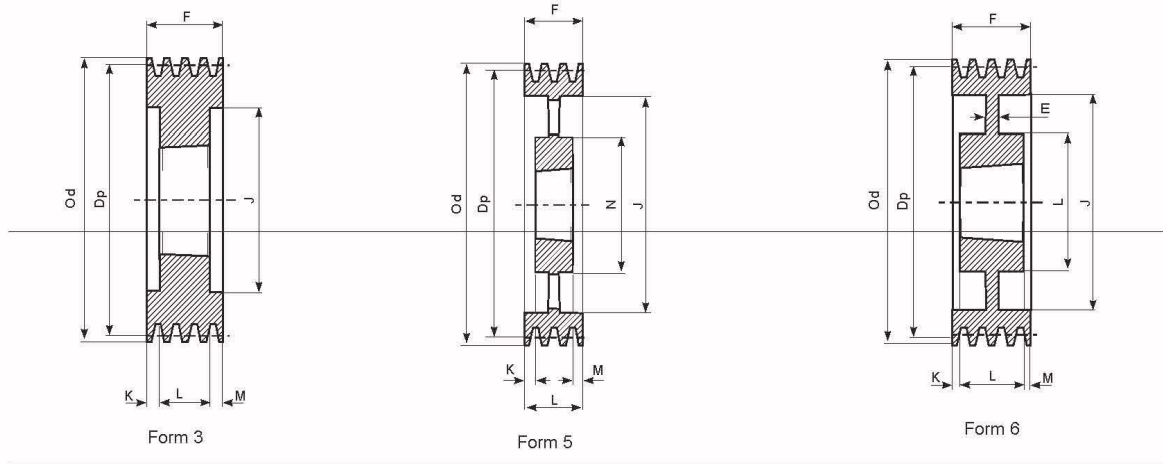

SPC - 6

Description	Dp.	Od.	Form	Bush No.	Max Bore	E	F	J	K	L	M	N
SPC 200x6	200	209,6	3	3535	90	-	162	144	36,5	89	36,5	-
SPC 212x6	212	221,6	3	3535	90	-	162	156	36,5	89	36,5	-
SPC 224x6	224	233,6	3	3535	90	-	162	168	36,5	89	36,5	-
SPC 236x6	236	245,6	3	3535	90	-	162	180	36,5	89	36,5	-
SPC 250x6	250	259,6	3	3535	90	-	162	194	36,5	89	36,5	-
SPC 265x6	265	274,6	3	3535	90	-	162	209	36,5	89	36,5	-
SPC 280x6	280	289,6	6	3535	90	20	162	224	36,5	89	36,5	175
SPC 300x6	300	309,6	6	3535	90	20	162	244	36,5	89	36,5	175
SPC 315x6	315	324,6	6	3535	90	20	162	259	36,5	89	36,5	175
SPC 335x6	335	344,6	6	3535	90	20	162	279	36,5	89	36,5	175
SPC 355x6	355	364,6	6	3535	90	20	162	299	36,5	89	36,5	175
SPC 375x6	375	384,6	6	4040	100	30	162	319	30	102	30	210
SPC 400x6	400	409,6	6	4040	100	30	162	344	30	102	30	210
SPC 425x6	425	434,6	6	4040	100	30	162	369	30	102	30	210
SPC 450x6	450	459,6	6	4545	110	30	162	394	24	114	24	242
SPC 475x6	475	484,6	6	4545	110	30	162	419	24	114	24	242
SPC 500x6	500	509,6	5	4545	110	-	162	444	24	114	24	242
SPC 530x6	530	539,6	5	5050	125	-	162	474	17,5	127	17,5	265
SPC 560x6	560	569,6	5	5050	125	-	162	504	17,5	127	17,5	267
SPC 630x6	630	639,6	5	5050	125	-	162	574	17,5	127	17,5	267
SPC 710x6	710	719,6	5	5050	125	-	162	654	17,5	127	17,5	267
SPC 800x6	800	809,6	5	5050	125	-	162	737	17,5	127	17,5	267
SPC 1000x6	1000	1009,6	5	5050	125	-	162	937	17,5	127	17,5	267
SPC 1250x6	1250	1259,6	5	5050	125	-	162	1187	17,5	127	17,5	267

V-Belt pulleys for taper bush according to ISO4183 and DIN2211 norms

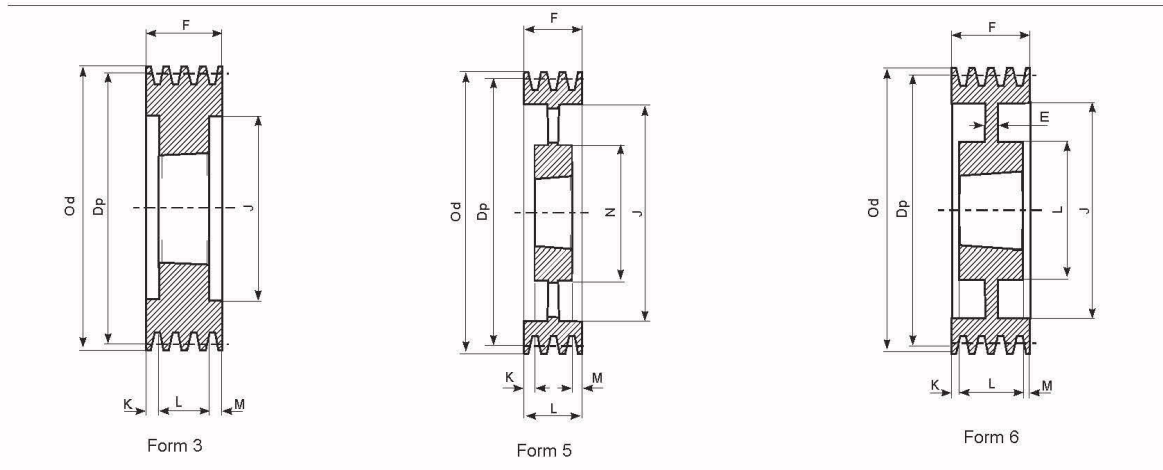

SPC - 8

Description	Dp.	Od.	Form	Bush No.	Max Bore	E	F	J	K	L	M	N
SPC 200x8	200	209,6	3	3535	90	-	213	144	62	89	62	-
SPC 212x8	212	221,6	3	3535	90	-	213	156	62	89	62	-
SPC 224x8	224	233,6	3	3535	90	-	213	168	62	89	62	-
SPC 236x8	236	245,6	3	3535	90	-	213	180	62	89	62	-
SPC 250x8	250	259,6	3	3535	90	-	213	194	62	89	62	-
SPC 265x8	265	274,6	3	3535	90	-	213	209	62	89	62	-
SPC 280x8	280	289,6	3	3535	90	-	213	224	62	89	62	-
SPC 300x8	300	309,6	3	4040	100	-	213	244	55,5	102	55,5	-
SPC 315x8	315	324,6	3	4040	100	-	213	259	55,5	102	55,5	-
SPC 335x8	335	344,6	6	4040	100	50	213	279	55,5	102	55,5	210
SPC 355x8	355	364,6	6	4040	100	40	213	299	55,5	102	55,5	210
SPC 375x8	375	384,6	6	4545	110	30	213	319	49,5	114	49,5	242
SPC 400x8	400	409,6	6	4545	110	30	213	344	49,5	114	49,5	242
SPC 425x8	425	434,6	6	4545	110	30	213	369	49,5	114	49,5	240
SPC 450x8	450	459,6	6	5050	125	30	213	394	43	127	43	267
SPC 475x8	475	484,6	6	5050	125	30	213	419	43	127	43	267
SPC 500x8	500	509,6	6	5050	125	30	213	444	43	127	43	267
SPC 530x8	530	539,6	6	5050	125	30	213	474	43	127	43	267
SPC 560x8	560	569,6	5	5050	125	-	213	504	43	127	43	267
SPC 630x8	630	639,6	5	5050	125	-	213	574	43	127	43	267
SPC 710x8	710	719,6	5	5050	125	-	213	654	43	127	43	267
SPC 800x8	800	809,6	5	5050	125	-	213	737	43	127	43	267
SPC 1000x8	1000	1009,6	5	5050	125	-	213	937	43	127	43	267
SPC 1250x8	1250	1259,6	5	5050	125	-	213	1187	43	127	43	267

V-Belt pulleys for taper bush according to ISO4183 and DIN2211 norms

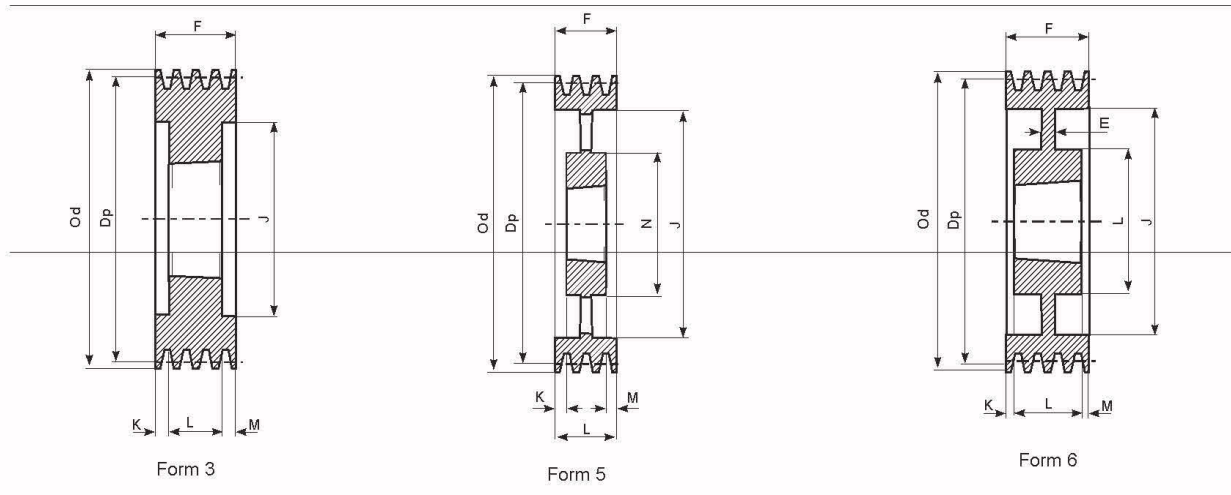

SPC - 10

Description	Dp.	Od.	Form	Bush No.	Max Bore	E	F	J	K	L	M	N
SPC 250x10	250	259,6	3	4040	100	-	264	194	81	102	81	-
SPC 280x10	280	289,6	3	4040	100	-	264	224	81	102	81	-
SPC 300x10	300	309,6	3	4545	110	-	264	244	75	114	75	-
SPC 315x10	315	324,6	3	4545	110	-	264	259	75	114	75	-
SPC 355x10	355	364,6	3	4545	110	-	264	299	75	114	75	-
SPC 400x10	400	409,6	6	5050	125	70	264	344	68,5	127	68,5	267
SPC 450x10	450	459,6	6	5050	125	40	264	394	68,5	127	68,5	267
SPC 500x10	500	509,6	6	5050	125	40	264	444	68,5	127	68,5	267
SPC 560x10	560	569,6	5	5050	125	-	264	504	68,5	127	68,5	267
SPC 630x10	630	639,6	5	5050	125	-	264	574	68,5	127	68,5	267
SPC 710x10	710	719,6	5	5050	125	-	264	654	68,5	127	68,5	267
SPC 800x10	800	809,6	5	5050	125	-	264	737	68,5	127	68,5	267
SPC 1000x10	1000	1009,6	5	5050	125	-	264	937	68,5	127	68,5	267
SPC 1250x10	1250	1259,6	5	5050	125	-	264	1187	68,5	127	68,5	267

Taper bushes
Standard stock bores metric series

Material: GG25

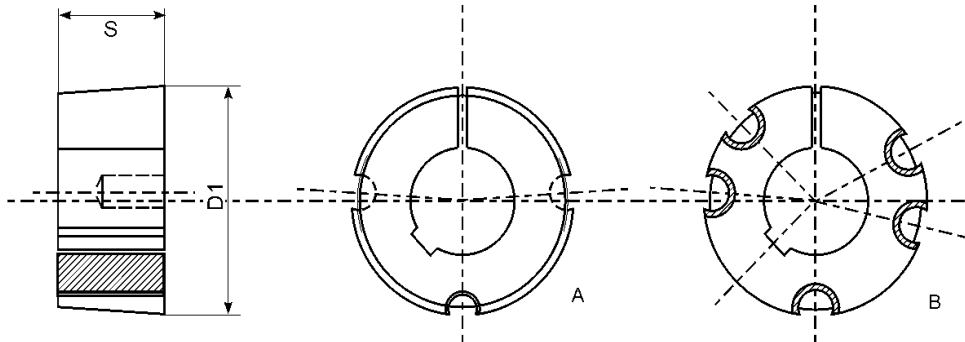

SIZE	BORE (ISO E 8)	Transm. Torque N/m	SCREWS B.S.W.	D1	TYPE	S
1008	9 10 11 12 14 16 18 19 20 22 24 25	5,6	1/4" x 1/2"	35,0	A	22,3
1108	9 10 11 12 14 16 18 19 20 22 24 25 28*	5,6	1/4" x 1/2"	38,0	A	22,3
1210	11 12 14 16 18 19 20 22 24 25 28 30 32	19,6	3/8" x 5/8"	47,5	A	25,4
1215	11 14 19 20 24 25 28 32	19,6	3/8" x 5/8"	47,5	A	38,1
1610	10 14 16 18 19 20 22 24 25 28 30 32 35 38 40* 42*	19,6	3/8" x 5/8"	57,0	A	25,4
1615	12 14 16 18 19 20 22 24 25 28 30 32 35 38 40* 42*	19,6	3/8" x 5/8"	57,0	A	38,1
2012	10 14 16 18 19 20 22 24 25 28 30 32 35 38 40 42 45 48 50*	30,4	7/16" x 7/8"	70,0	A	31,8
2517	10 16 18 19 20 22 24 25 28 30 32 35 38 40 42 45 48 50 55 60	48,0	1/2" x 1"	85,5	A	44,5
3020	15 25 28 30 32 35 38 40 42 45 48 50 55 60 65 70 75	90,0	5/8" x 1" 1/4	108,0	A	50,8
3030	25 35 38 40 42 45 48 50 55 60 65 70 75 80	90,0	5/8" x 1" 1/2	108,0	A	76,2
3525	35 38 40 42 45 48 50 55 60 65 70 75 80 90	113,0	1/2" x 1" 1/2	127,0	B	64,9
3535	35 38 40 42 45 48 50 55 60 65 70 75 80 85 90*	113,0	1/2" x 1" 1/2	127,0	B	88,9
4030	35 40 42 45 48 50 55 60 65 70 75 80 85 90 100*	169,0	5/8" x 1" 1/2	146,0	B	76,2
4040	35 40 42 45 48 50 55 60 65 70 75 80 85 90 100*	169,0	5/8" x 1" 3/4	146,0	B	101,6
4545	55 60 65 70 75 80 85 90 100* 110	192,0	3/4" x 2"	162,0	B	115,0
5050	60 70 75 80 85 90 100 105 110 115 120 125	272,0	7/8" x 2" 1/4	177,6	B	127,0

Dimensions of keyways with standard bore metric series

D		b	t
Over	to		
10	12	4	D + 1.8
12	17	5	D + 2.3
17	22	6	D + 2.8
22	30	8	D + 3.3
30	38	10	D + 3.3
58	65	18	D + 4.4
65	75	20	D + 4.9
75	85	22	D + 5.4
85	95	25	D + 5.4
95	110	28	D + 5.4
110	130	32	D + 7.4

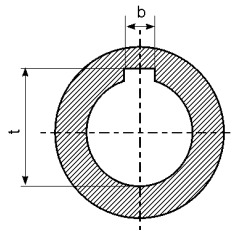

D	b	t
28*	8	D + 1.3
35*	10	D + 1.3
40*/42*	12	D + 1.3
50*	14	D + 2.8
90*	25	D + 3.4
100*	28	D + 5.4

Taper bushes

Material: GG25

Standard stock bores in inches

SIZE	BORE (ISO E 8)
1008	3/8 - 7/16 - 1/2 - 9/16 - 5/8 - 11/16 - 3/4 - 13/16 - 7/8 - 15/16 - 1" - 1"1/16* - 1"1/8*
1108	3/8 - 7/16 - 1/2 - 9/16 - 5/8 - 11/16 - 3/4 - 13/16 - 7/8 - 15/16 - 1" - 1"1/16* - 1"1/8*
1210	1/2 - 9/16 - 5/8 - 11/16 - 3/4 - 13/16 - 7/8 - 15/16 - 1" - 1"1/16 - 1"1/8 - 1"3/16 - 1"1/4 - 1"5/16 - 1"3/8
1215	1/2 - 9/16 - 5/8 - 11/16 - 3/4 - 13/16 - 7/8 - 15/16 - 1" - 1"1/16 - 1"1/8 - 1"3/16 - 1"1/4 - 1"5/16 - 1"3/8
1610	1/2 - 9/16 - 5/8 - 11/16 - 3/4 - 13/16 - 7/8 - 15/16 - 1" - 1"1/16 - 1"1/8 - 1"3/16 - 1"1/4 - 1"5/16 - 1"3/8 - 1"7/16 - 1"1/2 - 1"5/8*
1615	1/2 - 9/16 - 5/8 - 11/16 - 3/4 - 13/16 - 7/8 - 15/16 - 1" - 1"1/16 - 1"1/8 - 1"3/16 - 1"1/4 - 1"5/16 - 1"3/8 - 1"7/16 - 1"1/2 - 1"5/8*
2012	3/4 - 13/16 - 7/8 - 15/16 - 1" - 1"1/16 - 1"1/8 - 1"3/16 - 1"1/4 - 1"5/16 - 1"3/8 - 1"7/16 - 1"1/2 - 1"5/8 - 1"3/4 - 1"7/8 - 2"
2517	3/4 - 7/8 - 15/16 - 1" - 1"1/16 - 1"1/8 - 1"3/16 - 1"1/4 - 1"5/16 - 1"3/8 - 1"7/16 - 1"1/2 - 1"5/8 - 1"3/4 - 1"7/8 - 2" - 2"1/8 - 2"1/4 - 2"3/8 - 2"1/2*
3020	1"1/4 - 1"5/16 - 1"3/8 - 1"7/16 - 1"1/2 - 1"5/8 - 1"3/4 - 1"7/8 - 2" - 2"1/8 - 2"1/4 - 2"3/8 - 2"1/2 - 2"5/8 - 2"3/4 - 2"7/8 - 3"
3030	1"1/4 - 1"5/16 - 1"3/8 - 1"7/16 - 1"1/2 - 1"5/8 - 1"3/4 - 1"7/8 - 2" - 2"1/8 - 2"1/4 - 2"3/8 - 2"1/2 - 2"5/8 - 2"3/4 - 2"7/8 - 3"
3525	1"1/2 - 1"5/8 - 1"3/4 - 1"7/8 - 2" - 2"1/8 - 2"1/4 - 2"3/8 - 2"1/2 - 2"5/8 - 2"3/4 - 2"7/8 - 3" - 3"1/8 - 3"1/4 - 3"3/8 - 3"1/2
3535	1"1/2 - 1"5/8 - 1"3/4 - 1"7/8 - 2" - 2"1/8 - 2"1/4 - 2"3/8 - 2"1/2 - 2"5/8 - 2"3/4 - 2"7/8 - 3" - 3"1/8 - 3"1/4 - 3"3/8 - 3"1/2
4030	1"3/4 - 1"7/8 - 2" - 2"1/8 - 2"1/4 - 2"3/8 - 2"1/2 - 2"5/8 - 2"3/4 - 2"7/8 - 3" - 3"1/8 - 3"1/4 - 3"3/8 - 3"1/2 - 3"3/4 - 4*
4040	1"3/4 - 1"7/8 - 2" - 2"1/8 - 2"1/4 - 2"3/8 - 2"1/2 - 2"5/8 - 2"3/4 - 2"7/8 - 3" - 3"1/8 - 3"1/4 - 3"3/8 - 3"1/2 - 3"3/4 - 4*
4545	
5050	2"3/4 - 2"7/8 - 3" - 3"1/8 - 3"1/4 - 3"3/8 - 3"1/2 - 3"3/4 - 4* - 4"1/4 - 4"1/2 - 4"3/4 - 5"

Dimensions of keyways with standard bore in inches (B.S.46: PART 1:1958))

D		b	t
Over	to		
1/4	1/2	1/8	D + 1/16
1/2	3/4	3/16	D + 3/32
3/4	1"	1/4	D + 1/8
1"	1" 1/4	5/16	D + 1/8
1" 1/4	1" 1/2	3/8	D + 1/8
1" 1/2	1" 3/4	7/16	D + 5/32
1" 3/4"	2"	1/2	D + 5/32
2"	2" 1/2	5/8	D + 7/32
2" 1/2	3"	3/4	D + 1/4
3"	3" 1/2	7/8	D + 5/16
3" 1/2	4"	1"	D + 3/8
4"	5"	1" 1/4	D + 7/16
5"	6"	1" 1/2	D + 1/2
6"	7"	1" 3/4	D + 5/8

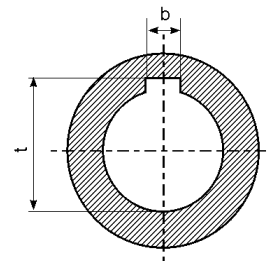

D	b	t
1"1/16* - 1" 1/8*	5/16	D + 5/64
1" 5/8*	7/16	D + 1/8
2"3/8* - 2"1/2*	5/8	D + 3/16
3"3/4* - 3"1/2*	7/8	D + 1/4
3"3/4* - 4**	1"	D + 1/4
5**	1"1/4	D + 5/16



sede centrale



magazzino 2



www.pizzirani.net



53034 Colle di Val D'Elsa (Si) Loc. San Marziale tel. +39.0577.909047 fax commerciale 0577.909049 fax acquisti 0577.908900 info@pizzirani.net
Informazioni tecniche, calcoli, preconizzazioni. - tecnica@pizzirani.net

distributore di zona:
area dealer: